

CONTENTS

SL NO	NAME OF EXPERIMENTS	PAGE NO
01	Identification of single core(SC),twin core(TC),three core(3C),four core(4C);copper and aluminium PVC,VIR &Weather proof(WP) wire and prepare Britannia T-joint and Married joint.	04-11
02	Cutting copper and aluminium cable and crimping lug to them from 4mm ² to 25mm ² ,cross section.	12-14
03	Connection and testing of fluorescent tube light,high pressure M.V. lamp , sodium vapour lamp,M.H. lamp, CFL and latest model lamp-measure inductance,Lux/lumens(intensity of illumination) in each case -prepare lux table.	15-23
04	Study battery charger and make charging of lead acid battery (record charging voltage, current and specific gravity).	24-27
05	Erection of residential building wiring by CTS and conduit Wiring system using main two points and test installation by test lamp method and a megger.	28-32
06	Fault finding & repairing of fan -prepare an inventory list of parts.	33-36
07	Find out fault of DC generator ,repair and test it to run.	37-40
08	Find out fault of DC motor starters and AC motor starter-prepare an inventory list of parts used in different starters.	41-48
09	Use crimping tools to lug sockets on L.T. & H.T. aluminium cable from 10mm ² to 50mm ² .	49-51
10	Dismantle, over haul and assemble a single phase induction motor .Test and run it-prepare an inventory list.	52-58

11	Dismantle over and assemble a three phase squirrel cage and phase wound motor. Test and run them.	59-61
12	Overhaul a single phase /3 phase variac.	62-64

EXPERIMENT NO:-01

AIM OF THE EXPERIMENT :-Identification of single core (ST), twin core (TC), three cores (3c), four cores (4c), copper and aluminium PVC, VIR & weather proof (WP) wire and prepare Britannia T joint and married joint.

MATERIAL REQUIRED: -

SL NO	NAME OF THE MATERIAL	SPECIFICATION	QUANTITY
1	PVC wire	7/22 swg,17 cm	2 piece
2	Sand paper		10 cm
3	Combinational pliers	15 cm, tap aria	1
4	Side cutting pliers	15 cm, tap aria	1
5	Steel ruler	12 inch	1
6	Try square		1
7	Electrician knife		1

Single core wire: -

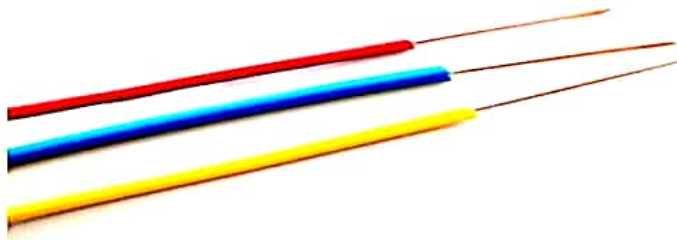

Single core cables are made up of a single conductor covered by a PVC insulation. They are mainly used in power and lighting circuits, both domestic and commercial applications. They are also used in the internal wiring of appliances suitable for installation in conduits and turning. Single core cables are a good conductor of electricity as well as heat. These cannot melt or burn easily.

A single core wire is a cylindrical strand of metal. In single core wire there is only a single core of metal is present, mostly copper or aluminum.

These wires are available in different thickness and gauges.

Twin core cable: -

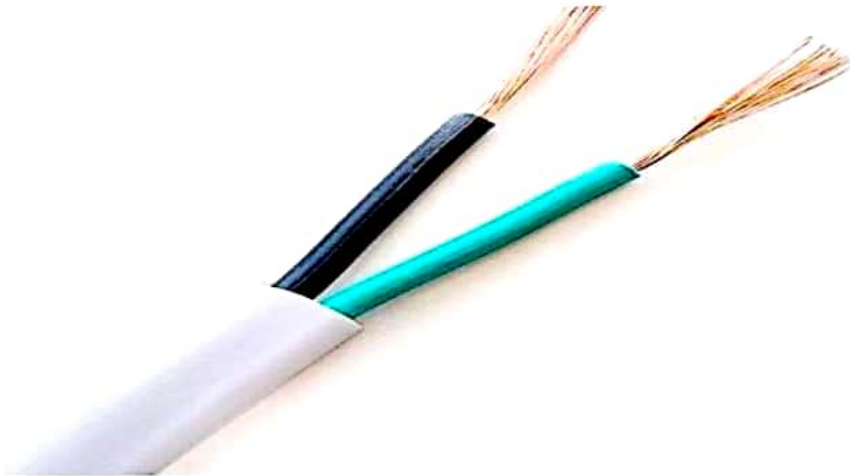

A range of flat thin wall twin core cables, suitable for automotive use.

Thin wall low voltage cable, suitable for use in automotive and marine applications consists of conductors of stranded copper wire which are hard grade PVC insulated. Compared to stranded PVC cable, the reduced insulation thickness and higher current capacity greatly reduces weight and volume. For these reason, this cable is today used in preference to stranded PVC cable by vehicle manufacturers.

Three core wire (3c):-



These cables are used generally for a perfect balanced 3 phase system. When the current on the 3 live wires of a 3 -phase are equal and at an exact 120-degree phase angle, then the

system is said to be balanced. The 3 phase loads are identical in all respects with no need of a neutral conductor.

Four core wire: -



When there is severe out of balance conditions, the amount of fault current will raise to a very high level. Generally, in the case of linear loads, the neutral only carries the current due to imbalance between the phases.

The nonlinear loads such as switch mode power supplies, computer, office equipment, lamp ballasts and transformers on low loads produce third order harmonic currents which are in the phase of all the supply phases.

These currents do not cancel at the star point of a three phase system as do normal frequency currents, but add up, so that the neutral carries very heavy third harmonic currents.

Procedure to prepare T joint in stranded PVC wire: -

- 1.Remove the insulation of main wire at the required length of nearly 5cm.
- 2.Remove the insulation of branch wire of length nearly 7.5cm.
- 3.Gently untwisted the stranded wire of pvc cable leaving 2cm from the cable.
- 4.Clean the wire with sand paper.
- 5.Separate the strands on each side and center one will be deleted to form as base.

6. Fit the main wire in between the equally divided strands of the branch cable so that the middle part of the main wire will be situated at the center point of the main wire in between the 2 equally divided branch wire.

7. Fold the joint normally in conductor.

8. Twist the strands with the help of the pliers.

9. The finished joint is the given figure.

14

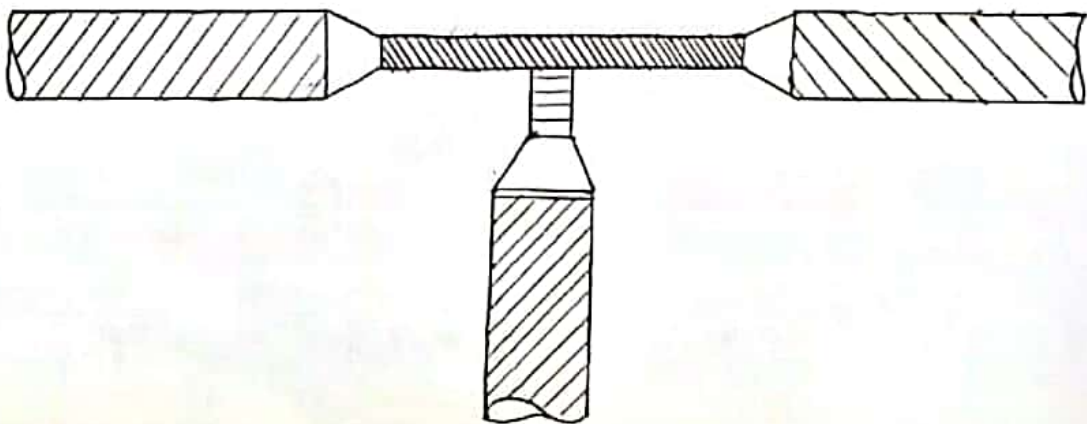
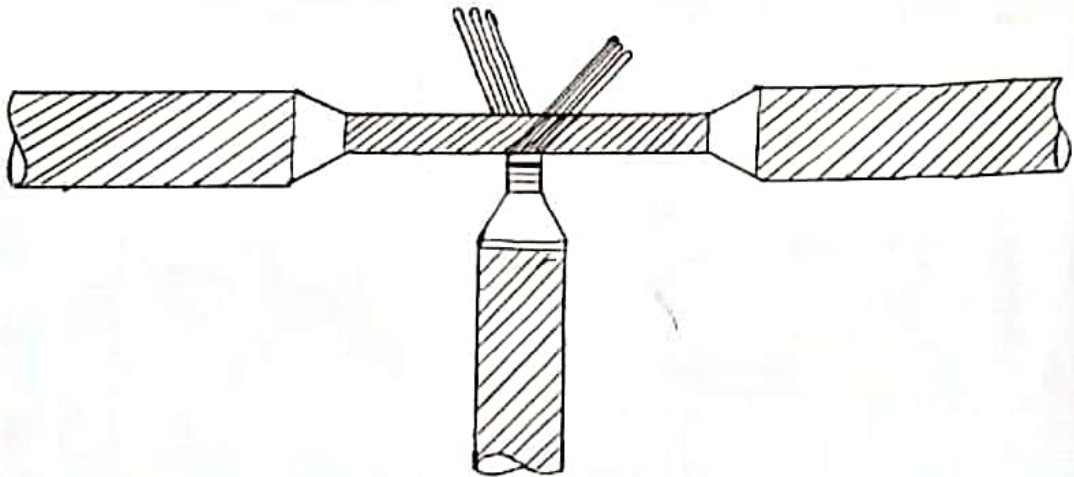
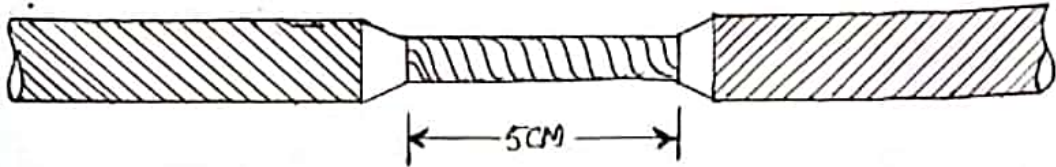
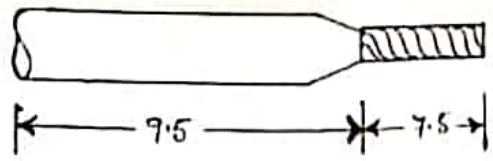
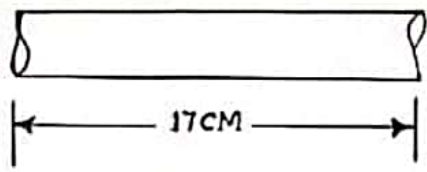

Procedure to prepare a married joint: -

1. Remove the insulation of the PVC wire of length 18cm from one of both wire.
2. Clean the strands with sand paper.
3. Gently untwist the strands of the PVC cable was cut.
4. The strands of both the PVC cable was cut.
5. The strands of both the PVC wire was untwisted in such a way that it looks like an equally spaced star.
6. Then the 2 equally spaced stars are brought together and again a equally spaced star is formed.
7. Then the 2 PVC wire are interlocked between the equally spaced star in such a way that all the strands of 1 PVC wire is twisted in one direction and the other strands of other PVC wire is twisted in the other or opposite direction.
8. Then the finished joint is shown in the figure.

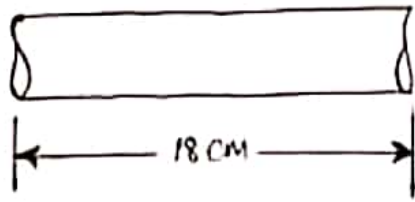

A. STRANDED PVC CABLE

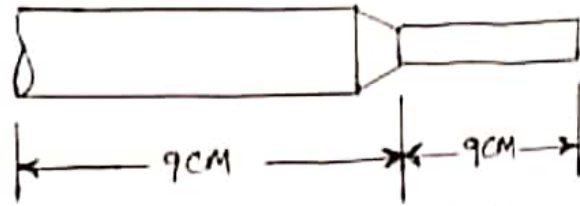

B. REMOVING OF INSULATION

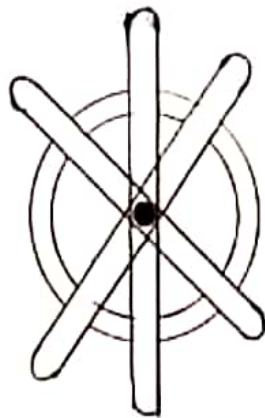

C. SPREADING OF STRANDS

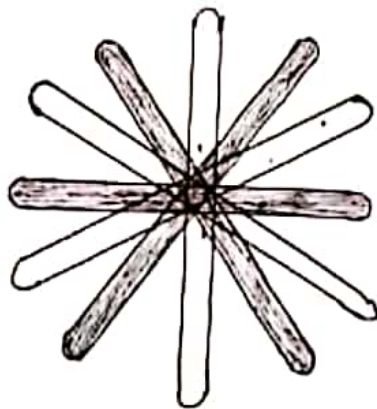

D. INSERTION OF TWO STRANDED PVC CABLE IN STAR FASHION LOOP IN SYSTEM, DISTRIBUTE CLEAT, T SYSTEM INTER WIRING ADVANTAGE AND DIS ADVANTAGE.

BRITANNIA T JOINT: -

The **Britannia joint** is a form of electrical **joint** used for bare overhead wires where great tensile strength is required. The two wires are each tinned, and then each have a short shoulder bent in them, and are then bound together with tinned wire before the whole is soldered.

PROCEDURE TO PREPARE BRITANNIA T JOINT: -

1. Remove the insulation
2. Bring the two conductors to a crossed position and then make a long bend or twist in each wire.
3. A Britannia splice isn't appropriate for stranded wire. A Britannia splice is used to connect 2 wires where there is a need to maintain high tensile strength, eg in overhead cables.
4. In the past this has been acceptable in interior wiring where a large enough terminal is not available.
5. A Britannia splice is where you make a 90-degree bend to make a shoulder at the end of each wire, you then place them back-to-back and wrap a smaller gauge wire around the whole thing.

BRITANNIA T- JOINT DIAGRAM

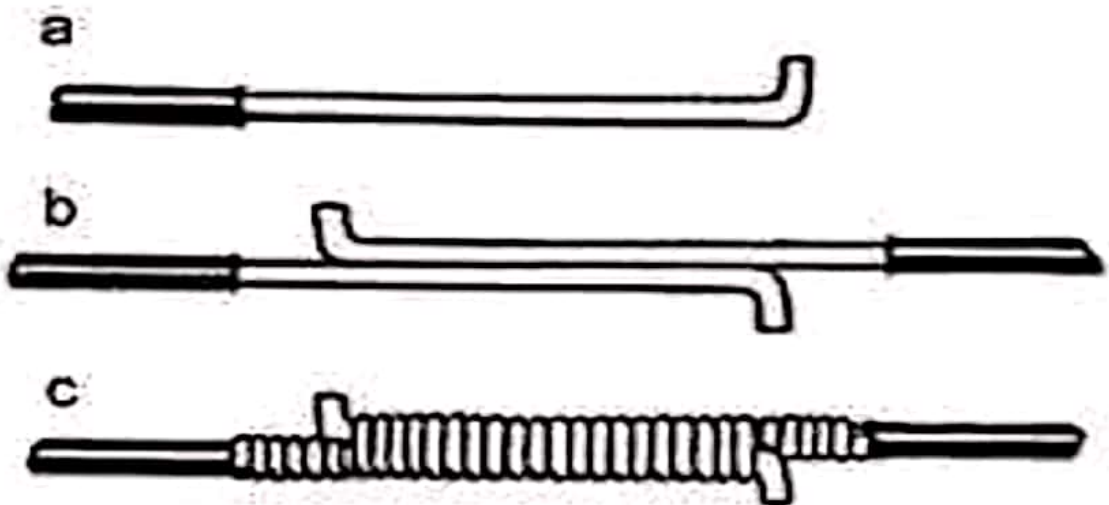

CONCLUSION: -

DISCUSION QUESTION: -

1. What is wire joint?
2. What is T-joint?
3. What is Britannia joint?
4. What are types of electrical joint?
5. What is married joint?

EXPERIMENT NO: - 02

Aim of the experiment:- Cutting copper and aluminium cable and crimping lug to them from 4mm² to 25mm² cross-section.

Apparatus Required:-

Sl No.	Name of equipment	Specification	Quantity
01.	Copper wire	1meter	1no
02.	Aluminium wire	1meter	1no
03.	Crimping lug	4mm ² -25mm ²	1no
04.	Cable cutter		1no

Theory: -

Crimping is joining two or more pieces of metal or other ductile material by deforming one or both of them to hold the other. The bent or deformity is called the crimp. To use this crimping tool in each wire is first placed into the connector. Once all the wires are in the jack, the connector with wires is placed into the crimping tools and the handles are squeezed together. Crimping punctures the plastic connector and holds each of the wires, allowing for data to be transmitted through the connector. Crimping tools are of different types such as 0.14mm to 10mm insulated and non-insulated type.

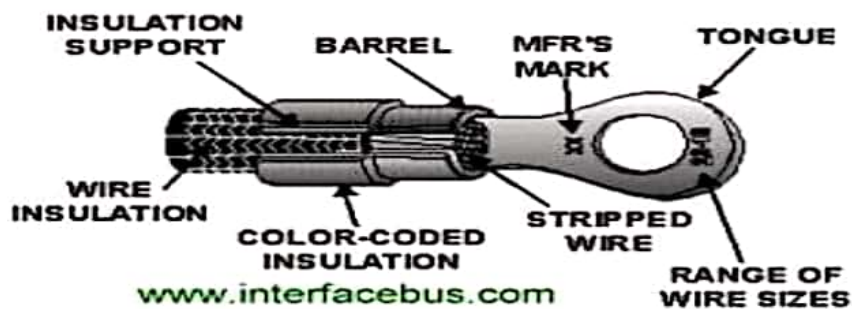

Common Crimper Types: -

- **Hand Crimper: -**

Hand Crimpers These handheld crimpers used for smaller wires. Some can also be used to cut strip wire as well.



- **Hydraulic Crimper: -**

Simply speaking, a hydraulic crimping tool is used to crimp, or connect, a connector to an end of a cable or hose



CONCLUSION: -

DISCUSSION QUESTION: -

- 1.** What is crimper?
- 2.** What is crimping lug?
- 3.** What is the use of crimping tool?
- 4.** What does crimping wire means?

EXPERIMENT NO: -03

AIM OF THE EXPERIMENT: -Connection and testing of fluorescent tube light, high pressure M.V. lamp, sodium vapor lamp, M.H. lamp, CFL and latest model lamp-measure inductance, lux/lumens (intensity of illumination) in each case - To prepare lux table.

A. connect and test connection of a fluorescent lamp.

TOOLS AND EQUIPMENT REQUIEDS: -

SL NO.	NAME OF THE TOOLS AND EQUIPMENTS	SPECIFICATION	QUANTITY
01	Fixing channel along with tube light holder at two ends of the channel		1set
02	Choke	40w,240v	1 no
03	Blow type starter	240v	1no
04	Fluorescent tube	40w,240v	1no
05	Connecting wire	3/22swg	As per required
06	Insulated pliers	15cm,taparia	1no
07	Insulated screw driver	15cm,taparia	1no
08	Insulated cutter	15cm,taparia	1no
09	Tester	0-500v	1no
10	E. knife		1no

THEORY: -

Fluorescent light has great advantages over other light sources in a many applications. Its shape is like a tube and fluorescent powder is coated inside the tube so it is called fluorescent tube. Such as the tube can be obtained in a variety of lengths, with illumination in a variety of colour .The efficiency of fluorescent lamp is about 40 lumens/watt. Various fluorescent materials give different colour of lights. It also provided with two electrodes inside the discharge tube coated with electron emitting materials. The mercury vapour with small quantity of argon gas at low pressure is filled up in the tube.

A starting switch also known as a starter connection in series with the fluorescent lamp whose function is to initiate the discharge inside the tube during starting . The choke is also connected in series with the fluorescent tube whose function is to maintain or stabilized the voltage during running condition and provide a voltage impulse during starting. The capacitor is also connected across the circuit to improve the power factor which was reduced due to the presence of ballast.

CIRCUIT DIAGRAM:-

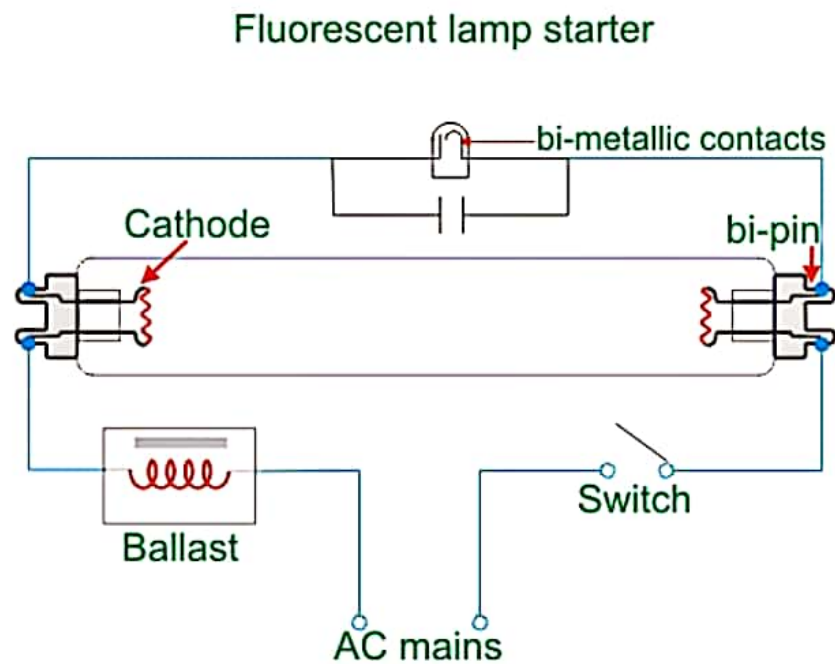

(CIRCUIT DIAGRAM OF CONNECTION OF FLUORESCENT TUBE)

WORKING PROCEDURE: -

- At first the connection diagram was studied and then connected as per circuit diagram.
- The starter was connected across the two terminal of the fluorescent lamp.
- The choke was connected in series with the fluorescent lamp.
- A tube light or fluorescent lamp of 40w was fixed in the frame.
- The connection was checked was once again for, if any loose connection.
- The ac supplied across the 2 output terminal as per circuit diagram.

B. connection and testing of high pressure mercury vapour lamp

EQUIPMENTS REQUIRED: -

SL NO	NAME OF THE EQUIPMENTS	SPECIFICATION	QUANTITY
01	choke or ballast	125w,phllips ,200/240v	1no
02	High pressure mercury vapour(HPMV)lamp	MV type 125w,200/240v	1no
03	Capacitor	2.5 μ f	1no
04	Holder	3 pin type MV type	1no
05	Connecting wire	3/22swg	As per required

THEORY: -

It consists of evacuated glass bulb with another hard glass evacuated glass tube in which two oxide coated tungsten filament are placed at each end of the tube. A starting electrode near the upper main electrode(filament) through high resistance in series is placed. Inside the tube small quantity of mercury and low pressure argon gas is filled up. Three pin bayonet cap or screw type cap is provided for connection and holding bulb in the holder.

The bulb is connected to AC supply through choke having different tapping for adjustment as per supply voltage to provide high voltage at the time of starting to upper main electrode and starting electrode which discharge the gas and provide path for the flow of electron through main electrodes because of low resistance and gives yellow blue light at time for starting. After complete discharge of gas and vaporization of mercury, it gives white light bluish light within 3 to 5 minutes.

- It can only use in vertical position.
- It can only be used on AC supply.
- It is used for street lighting, railway yards, and decoration purposes etc.

The efficiency is about 30-40 lumen/watt. These lamps are manufactured in 80,125,250,400 and 1000watts etc rating for use on 200-250volts ac supply mains. The main function of choke is to control the voltage i.e., provide high voltage at the time of starting and low voltage in normal working condition.

CIRCUIT DIAGRAM:-

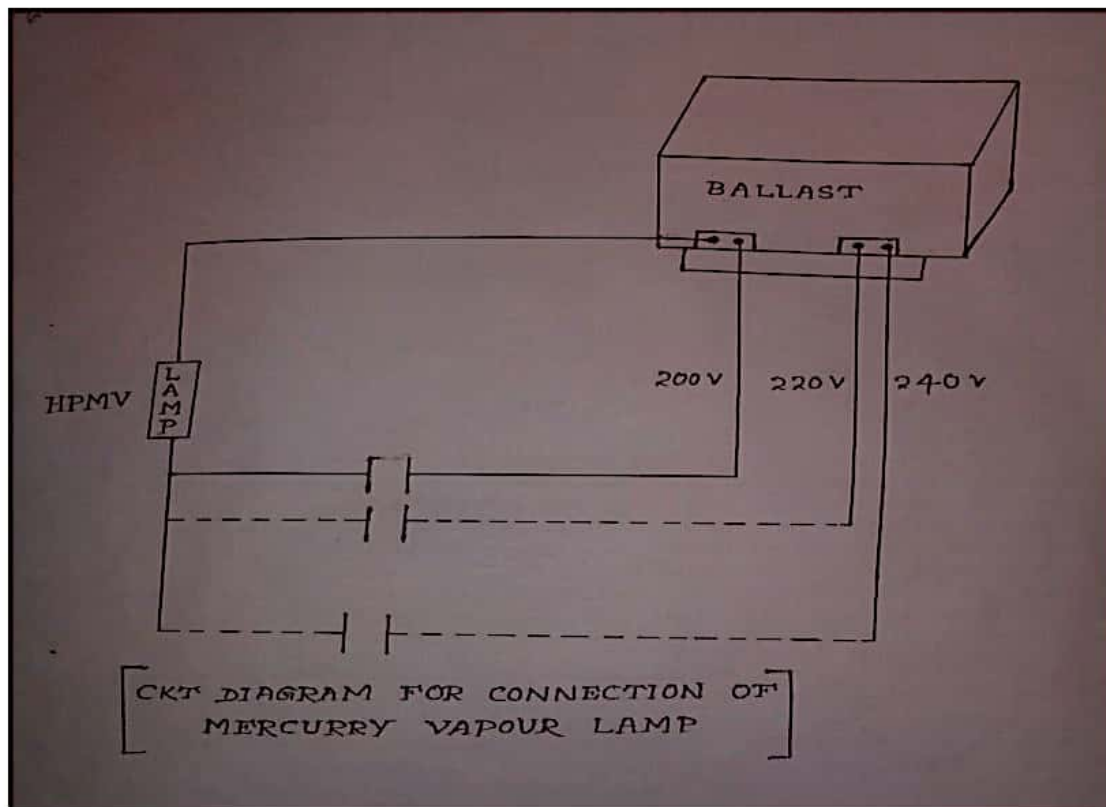

WORKING PROCEDURE:-

- ❖ At first all the apparatus was connected as per circuit diagram.
- ❖ Then all the connections checked properly.
- ❖ The mercury vapour lamp was then fixed in the holder.
- ❖ Any loose connection at ballast and holder were checked.
- ❖ The supply was then switched ON.

C. Connecting and testing of a sodium vapour lamp.

APPARATUS REQUIRED:-

SL NO	NAME OF THE EQUIPMENTS	SPCIFICATION	QUANTITY
01	Choke or ballast	Bajaj,220/240v,70w,10A	1no
02	Electronic igniter	Bajaj ,240v,50Hz,70w	1no
03	Lamp	SV lamp,200-250v,70w,Philips	1no
04	Holder	SV type	1no
05	Capacitor	2.5 μ f,50Hz	1no
06	Connecting wire	3/22swg	As per required

THEORY:-

Sodium vapour lamp is one of the types of electric discharge lamp. Sodium vapour lamp has the highest theoretical luminous efficiency and gives monochromatic orange yellow or brown yellow colour. The charge tube contains a thin coating of sodium metal on its inner layer and a trace of neon gas. Two oxide coated electrodes are sealed in to it and its other two ends are projected out. The sodium below 60°C is in solid state.

For starting the lamp, higher voltage about 380 to 450 volt is required, so for that a special type transformer known as reactance transformer or leaky transformer having poor voltage regulation is used which supplies higher voltage at starting and then with decrease in resistance of gas after discharge the current increase in tube. Thus, transformer gives normal working voltage about 110v. Due to use of poor regulation transformer, the power factor of the circuit falls and for that a capacitor is connected in parallel to supply to improve the power factor.

During starting time, it gives reddish light due to discharge of neon gas and then sodium crystal turns into vapour from and gives yellow-pink light.

- The bulb should be used in horizontal position.
- It can be used on AC supply.
- It is normally used for street lighting and sea shore lighting etc.
- **CIRCUIT DIAGRAM:-**

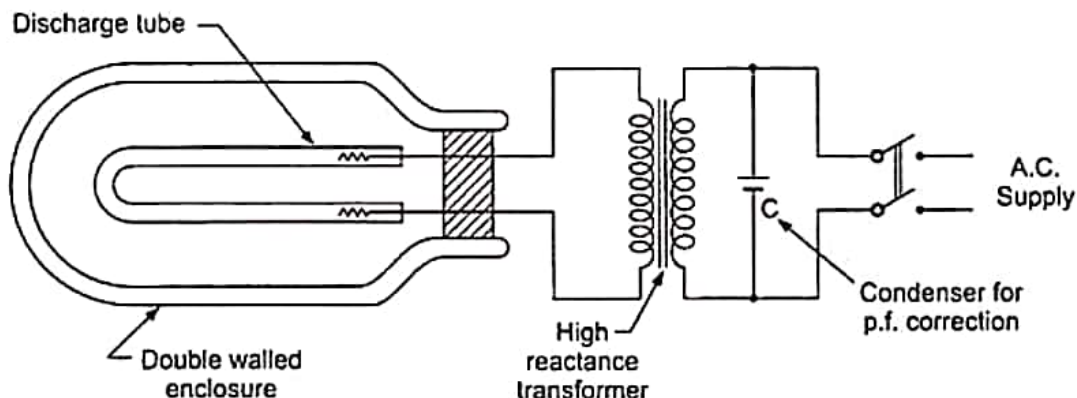

Fig. 7 Sodium vapour lamp

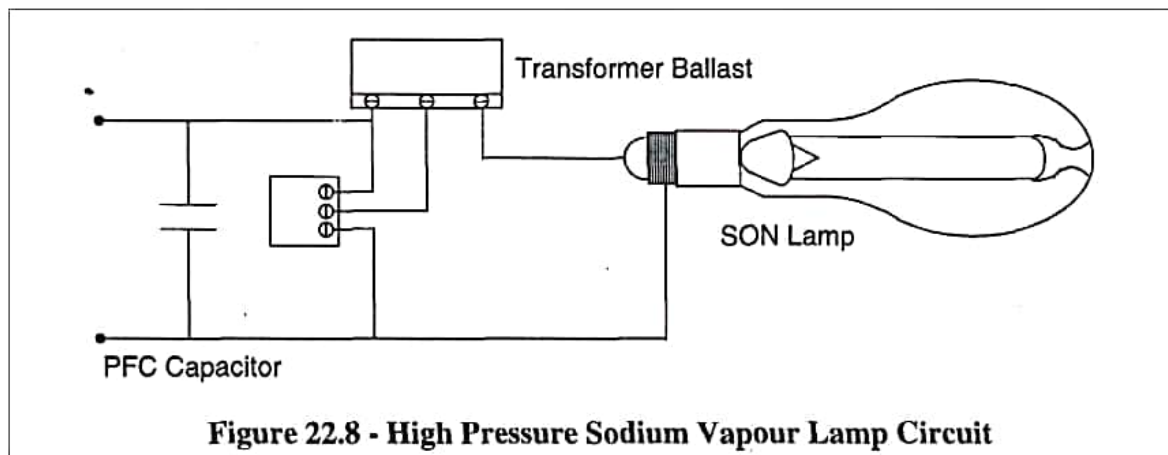

Figure 22.8 - High Pressure Sodium Vapour Lamp Circuit

WORKING PROCEDURE: -

1. At first all the apparatus was connected as per circuit diagram.
2. Then all the connections were checked properly.
3. Any loose connections at choke, ballast and holder are checked properly.
4. The capacitor was also connected as per circuit diagram.
5. The supply was switch ON.

D.METAL HALIDE LAMP (MH LAMP):-

Metal halide lamp is special type of arc discharge lamp that works on the arc stream via some iodide salts along with argon gas and mercury vapor pressure at several milli meters with the arc tube temperature of 1000K. Dr. Reiling had discovered Metal Halide Lamp in 1960

THEORY:-

- When full voltage is applied across the main electrodes, no arc is produced at the time of switching.
- The auxiliary electrode or starter electrode near the main electrodes attached to the glass stem creates initial discharge between them.
- A bimetal switch is there to short the starter electrode to the main electrode just at the time of starting.
- Starter electrode is used to create initial arc between main and auxiliary electrode that heats up the metal halide salts.
- Starter electrode or auxiliary electrode is of high resistance to limit the current at initial arc.

- Again discharge is first in argon and then in mercury.
- Small amount of mercury vapor helps to establish main arc formation between main electrodes through metal halides vapor one by one.
- To reach up to full light output this lamp takes 5 minutes.

DIAGRAM OF METAL HALIDE LAMP: -

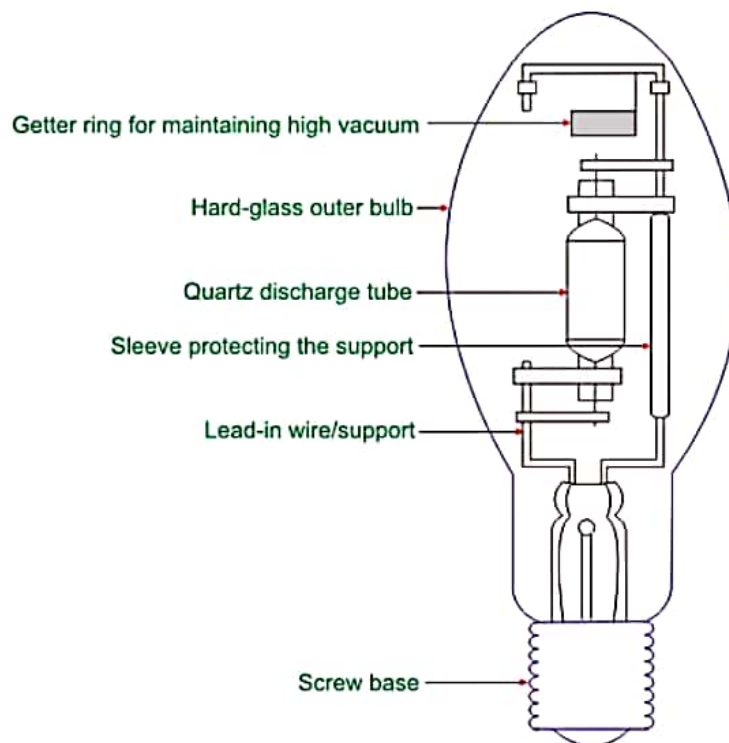

E. COMPACT FLUORESCENT LAMPS (C.F.L.):-

It is a modified form of fluorescent tube having all the positive feature of an ordinary bulb and tube light .It consumes 80% less electricity than an ordinary bulb and it has about six times longer life . It can be operated from 170v to 250v . It can be fitted with normal bulb holder . These are available in different range of shapes and sizes like pear shaped , globe shaped , etc. These are available in variety of wattages such as 5w,7w,9w,11w,15w,17w,20w,23w,etc.These also known as C.F.L.

DIAGRAM OF CFL LAMP:-

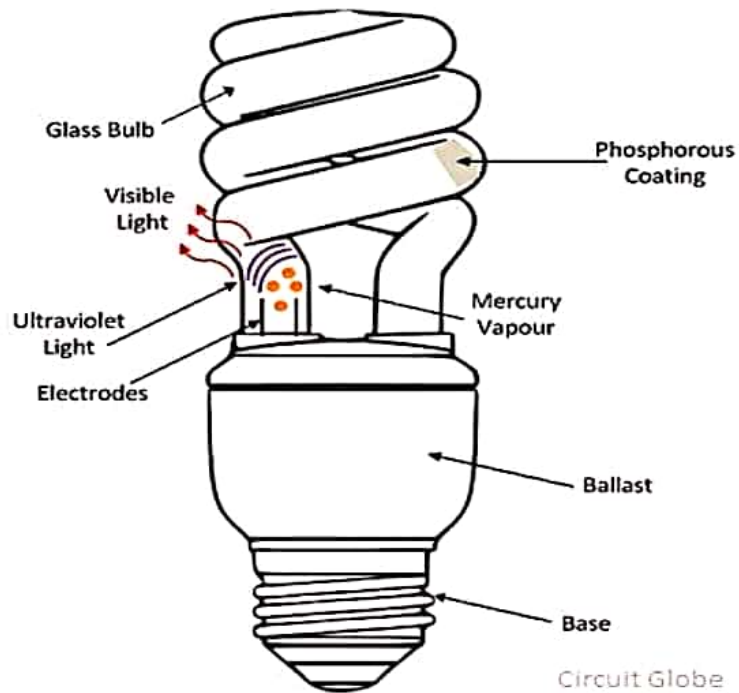

SAFETY AND PRECAUTION: -

- I. Connection should be proper and tight.
- II. Lamp terminal should be connected with the choke correctly.

CONCLUSION: -

DISCUSSION QUESTION: -

1. What is fluorescent lamp?
2. Why mercury is used in fluorescent lamp?
3. What is mercury light?
4. How does a MV lamp give a pink colour at the start?
5. Why sodium vapour lamp is yellow?
6. How does sodium vapour lamp work?

EXPERIMENT NO: -04

AIM OF THE EXPERIMENT: -

Study battery charger and make charging of lead acid battery.

APPRATUS REQUIRED: -

SL NO	NAME OF EQUIPMENT	SPECIFICATION	QUANTITY
01	Bridge rectifier		

02	Resistors	1kΩ(5w)	1no
03	Resistors	1kΩ	2no
04	Resistors	1.2kΩ	1no
05	Resistors	1.5kΩ	2no
06	Resistors	10kΩ	1no
07	Diodes	1N4007	3NO
08	Diodes	1N4732A	
09	NPN transistor		Asper required
10	LED		4
11	Potentiometer	50kΩ	

THEORY:-

Battery charger:-

A battery charger, or recharger, is a device use to put energy into a secondary cell or rechargeable battery by forcing an electric current through it. A trickle charger provides a relatively small amount of current, only enough to counteract self-discharge of a battery that is idle for a long time.

Lead acid battery charger:-

Lead Acid Batteries are one of the oldest rechargeable batteries available today. Due to their low cost (for the capacity) compared to newer battery technologies and the ability to provide high surge currents (an important factor in automobiles), Lead Acid Batteries are still the preferred choice of batteries in almost all vehicles.

The main concern with any battery is it discharges over time and must be recharged so that it can provide the necessary voltage and current. Different batteries have different strategies of charging and in this project, I will show you how to recharge a lead acid battery using a simple Lead Acid Battery Charger Circuit.

Circuit diagram:-

The circuit diagram of the Lead Acid

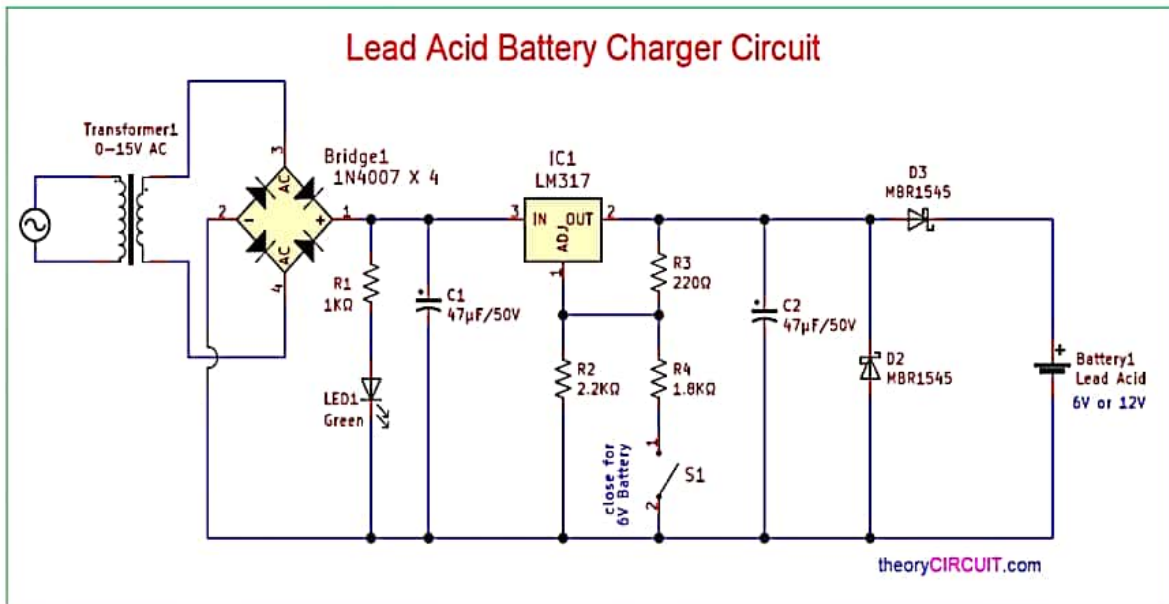

How to Recharge a Lead Acid Battery?

To charge a battery from AC we need a step down transformer, a rectifier, filtering circuit, regulator

to maintain the constant voltage. Then we can give the regulated voltage to the battery to charge it. Think if you have only DC voltage and charge the lead acid battery, we can do it by giving that DC voltage to a DC-DC voltage regulator and some extra circuitry before giving to the lead acid battery. Car battery is also a lead acid battery.

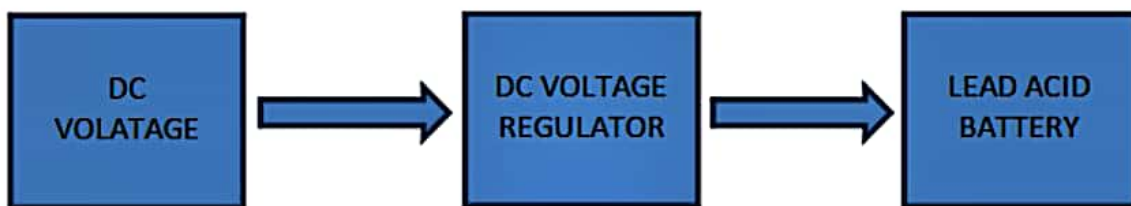

BLOCK DIAGRAM OF CHARGER FOR LEAD ACID BATTERY

A battery charger, or recharger, is a device use to put energy into a secondary cell or rechargeable battery by forcing an electric current through it. A trickle charger provides a relatively small amount of current, only enough to counteract self-discharge of a battery that is idle for a long time

As seen in the above block diagram, a DC voltage is given to the DC voltage regulator. The voltage regulator used here is 7815, which is a 15V regulator. The regulated DC out voltage is given to battery. There is also a trickle charge mode circuitry which will help to reduce the current when the battery is fully charged.

Circuit Explanation:-

- The circuit mainly consists of a Bridge rectifier (if you are using AC supply stepped down to 18V), 7815 Regulator, Zener Diode, 12V Relay and a few resistors and diodes.
- The DC voltage is connected to the Vin of the 7815 and starts charging the battery through the relay and the 1Ω (5W) resistor.
- When the charging voltage of the battery reaches the tripping point i.e. 14.5V, the Zener diode starts conducting and provides enough base voltage to transistor.
- As a result, the transistor is active and its output becomes HIGH. This high signal will activate the relay and the battery is disconnected from the supply.

NOTE:

- The battery should be charged with 1/10th its charging current. so the voltage regulator must generate 1/10th of the charging current produced by the battery.
- Heat sink should be attached to the 7815 Regulator to get the better efficiency.

CONCLUSION:-

DISCUSSION QUESTION:-

1. How a lead acid battery charger is made ?
2. What is the life of a lead acid battery ?
3. What is need of lead acid battery ?
4. What is the advantages of lead acid battery?
5. What do lead acid battery die ?

EXPERIMENT NO:05

AIM OF THE EXPT: -

Erection of residential building wiring by CTS and conduit wiring system using main two points and test installation by test lamp method and megger

APPARATUS REQUIRED: -

SL NO.	NAME OF EQUIPMENT	SPECIFICATION	QUANTITY
1	Main switch	240V/32A	1no.
2	Single way switch	5A,230V, & 15A	7nos.

3	3 pin socket	5A,230V & 15A	5nos.
4	FAN regulator	60watt	1no.
5	Ceiling rose	5A, 230V	1no.
6	Copper wire	—	As per reqd
7	Earth wire	1.5mm ²	As per reqd
8	Wooden screw	1/2"	As per reqd
9	Angle Holder	5A, 230V	1no
10	Batten holder	5A, 230V	1no
11	Switch		
12	Lamp		
13	Wire		
14	Fuse		

TOOLS REQUIRED:-

SL NO.	NAME OF THE TOOLS WITH FULL SPECIFICATION	QUANTITY
1	Insulated combination plier(TAPPARIA)	2no
2	Insulated screw driver(TAPPARIA)	2no
3	Insulated screw driver	1no
4	Hand drill	1no
5	Tester	1no

6	Knife	1no
7	Insulated Cutter	1no

Theory:-

C.T.S. (Cable Type Sheathed) wires: In this type, ordinary insulated conductors are provided with an additional tough rubber sheath. This also provides a protection against moisture, chemical fumes and tear.

Type of Conduit Wiring: Depending upon whether the conduits are laid inside the wall or supported on the walls, there are two types of conduit wiring.

i) Surface Conduit Wiring: In this method, conduits are fixed on the wall by means of saddles screwed to rawl π plugs or wooden plugs embedded in the wall. In damp situation, these conduits are spaced apart from the wall surface by small wooden blocks fixed below the pipe at regular intervals as illustrated

ii) Concealed Conduit Wiring: This method employs heavy gauge rigid conduits buried under wall plaster. Such wiring is used in case where beauty is the main consideration irrespective of cost.

Application: Surface conduit wiring is mainly used for all indoor and outdoor wiring of permanent nature for light and power e.g. in godowns, workshops and public

buildings. The concealed type is preferably used in public building, offices, shops and houses for its nice appearance.

The Domestic supply system is a 230v, 1 phase system. The 3 phase, 400v, 50c/s AC distributors. Running through every street cater to the electricity needs of every house hold.

From the service mains, a phase wire & a neutral wire are taken & run to each house, through a cutout or fuse placed in the phase line. These wires are fed through a sealed electricity energy meter (kwit meter) to a main switch from where it is taken to a branch distribution box. From this box the wiring of various house hold circuit are taken. The IE rules no 32 states that an indication of permanent natures shall be provided to distinguish neutral conductor from a line conductor. Red color a for line wire (i.e. live wire) & Black for earth neutral. In a 3 Core Cable feeding portable apparatus Red will be for the phase, Black for the earthed neutral & white for the earth Continuity wire.

The wiring may be done in various ways. The wires may be VIR (Vulcanized Indian Rubber) or PVC (Polyvinyl chloride) or CTS (cable type sheathed) Cable

Conduit wiring is perhaps best from point of view of eventuation of fire hazards of these are totally enclosed. metal sheath wiring is the next best PVC cables are less combusive than VIR wire, From point of view of cheaper cost .wiring comes first followed casing & capping. CTS wiring sheath & finally conduit wiring.

In house wiring there are certain precautions to be followed.

* In a neutral conductor must be replaced by a link. If fuses of the same capacity are provided one on the phase line & the other on the neutral line when a short CKT occurs one of them will blow out first any one of the two. If the fuse on the neutral will blow, the faulty apparatus will continue to be live the phase line fuse will be intact. Hence replace the neutral side fuse holder by a link.

The single pole tumbler switches used frequency must be connected in the phase line only through an witch is equally effective whether it is the neutral line of the phase from the point of view of safety the switch must be on the phase conductor & not on the neutral (IE rule 32)The reason is the switch he in the neutral line, the apparatus us well as part of the wiring will be line even when the switch is open i.e, off the switch position will dissipative may give a false sense of security of however the switch being the phase line & be off the equipment will be dead.

Control of One Lamp :-

Apparatus: Switches, lamps, wires, & fuse.

Wiring diagram: for controlling the lamp L, a single pole switch A is introduced in its circuits as shown in fig

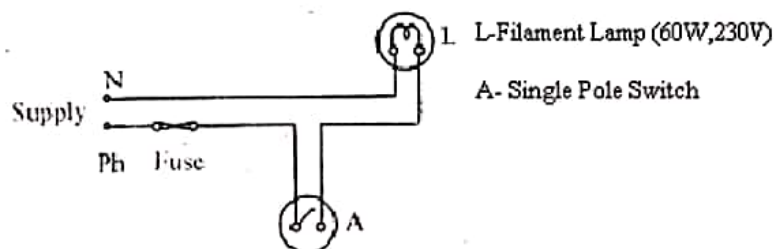

Wiring diagram for control of one lamp by one single pole switch

The live or phase wire is always connected to the lamp holder through the switch, whereas, neutral is connected directly to it. All the accessories such as a single pole switch, lamp holder, etc. are always fitted on the teak wood round block.

Working: When the switch is turned on, a full supply voltage is applied across the lamp terminals and the lamp glows. Thus, the lamp can be independently controlled by the single pole switch.

Application: the circuit is used for single room wiring.

Testing of Wiring Installations Using Megger:-

It is necessary to carry out the following tests on a wiring installation before it is put into service.

Insulation Resistance to Earth: Insulation resistance between all the conductors and earth is measured with the help of a 500 V megger as illustrated in Fig. 1.17. With all fuse links in position, all switches on (except main switch which should be off) and all lamps in position, the line terminal of the megger is connected to either of the main leads (phase or neutral) and the earth terminal is connected to any point on the earth continuity conductor of the system. Handle of the megger is then rotated and its reading is noted down. This reading directly gives the insulation resistance between all the conductors and earth. This resistance should not be less than $50 \text{ M}\Omega$ divided by the number of outlets (every switch, socket and lamp holder counting as an outlet). However, for installations using P.V.C. insulated cables, it should not be less than

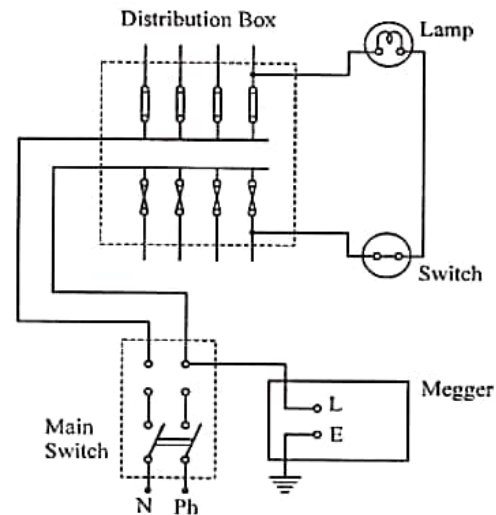

Measurement of insulation resistance to earth

12.5 $\text{M}\Omega$ divided by the number of outlets. It is desirable that the insulation resistance should be more than $1 \text{ M}\Omega$ for the entire installation. For motors and large lighting installations, maximum leakage current allowed is not to exceed $1/5000$ part of the full load current. Hence, minimum insulation resistance required may also be calculated from this limiting value of leakage current.

12.5 $\text{M}\Omega$ divided by the number of outlets. It is desirable that the insulation resistance should be more than $1 \text{ M}\Omega$ for the entire installation. For motors and large lighting installations, maximum leakage current allowed is not to exceed $1/5000$ part of the full load current. Hence, minimum insulation resistance required may also be calculated from this limiting value of leakage current.

Insulation Resistance between Conductors: Insulation resistance between the two conductors (phase and neutral) of the wiring installation is also measured with the help of a megger. With all fuse links in position, all switches on (except main switch which should be off) and all lamps and appliance out, megger terminals are connected between the two conductors as shown in Fig.1.18. Reading of the megger under this condition gives the insulation resistance between the two conductors under test. The resistance should not be less than that specified in the previous test.

(c) **Continuity Test:** Continuity of any wire used for wiring installation or of any circuit in the wiring installation can be checked with the help of a megger. For this, the megger terminals are connected to the two ends of the wire or circuit under test

The handle of the megger is then rotated. If the pointer indicates zero resistance, then the wire or the circuit is continuous (or unbroken). If, however, the pointer shows infinity reading, then the wire or the circuit is faulty (or open-circuited).

FISHING:-

It is the use of a weighted chain to guide a wire or conductor through a hole in the plate of a wall to prevent unnecessary wall damage or removal when remodeling the wiring in existing homes and buildings. A thin nylon rod is sometimes used in a reverse process to push through

the openings instead, and some refer to all procedures used to install wiring in existent walls as fishing. A long thin metal tape of study construction called a fish tape is frequently used to pull wires through pre-existing conduits by electricians.

A drawback is that the work is done blindly through enclosed spaces that may contain sharp objects that potentially cause damage to the wires including the possibility of hidden arc-faults.

CONCLUSION:-

From the above experiment we studied about the residential building practical for conduit wiring & testing.

DISCUSSION QUESTION:-

1. What is CTS?
2. What is conduit wiring?
3. What is the use of a megger?
4. What do you mean by fishing?
5. Write about types of wiring?

EXPERIMENT NO-06

AIM OF THE EXPERIMENT: -

Fault finding and repairing of fan and observation of different parts.

APPARATUS REQUIRED

Sl.no	Name	Specification	Quantity
1	Ceiling Fan	1Ø230v,50Hz,60W	1no
2	Insulated Plier	15cm insulated	2no
3	Screw Driver	15cm	2no

THEORY:-

1. What do you do if your fan stops working?

The faults which are occurred inside a ceiling fan, they are-

- i. Damage of winding insulation due to over heating or short circuit fault.
- ii. Slow speed of fan due to weak capacitor.
- iii. Some unwanted noise due to bearing faults, cracking of shaft, cracking of blade etc.
- iv. Reverse rotation due to wrong connection of capacitor and the terminal of fan.

Repair-

- i. At first check continuity of winding by series lamp method. If it is not working then we should rewinding the fan.
- ii. If the capacitor is weak then it is replaced.
- iii. If any fault occurred inside the bearing then either it is replaced or greased it (put some lubricants).
- iv. If any fault is occurred in shaft or blade then it is replaced.
- v. Reverse rotation can be removed by accurate connection between terminals of fan capacitor.

2. How to fix fan blades that won't turn?

- i. Turn your fan on and listen for the engine of the fan.
- ii. Make sure the fan is unplugged.
- iii. Look at where the fan blade unity connects to the bearing and motor.
- iv. Remove the center café from the fan blade unity.
- v. Press the strand that come with your metal lubricant spray in to the nozzle of the fan.

DIAGRAM

ROTOR OF CEILING FAN:-



DIFFERENT PARTS OF CEILING FAN:-

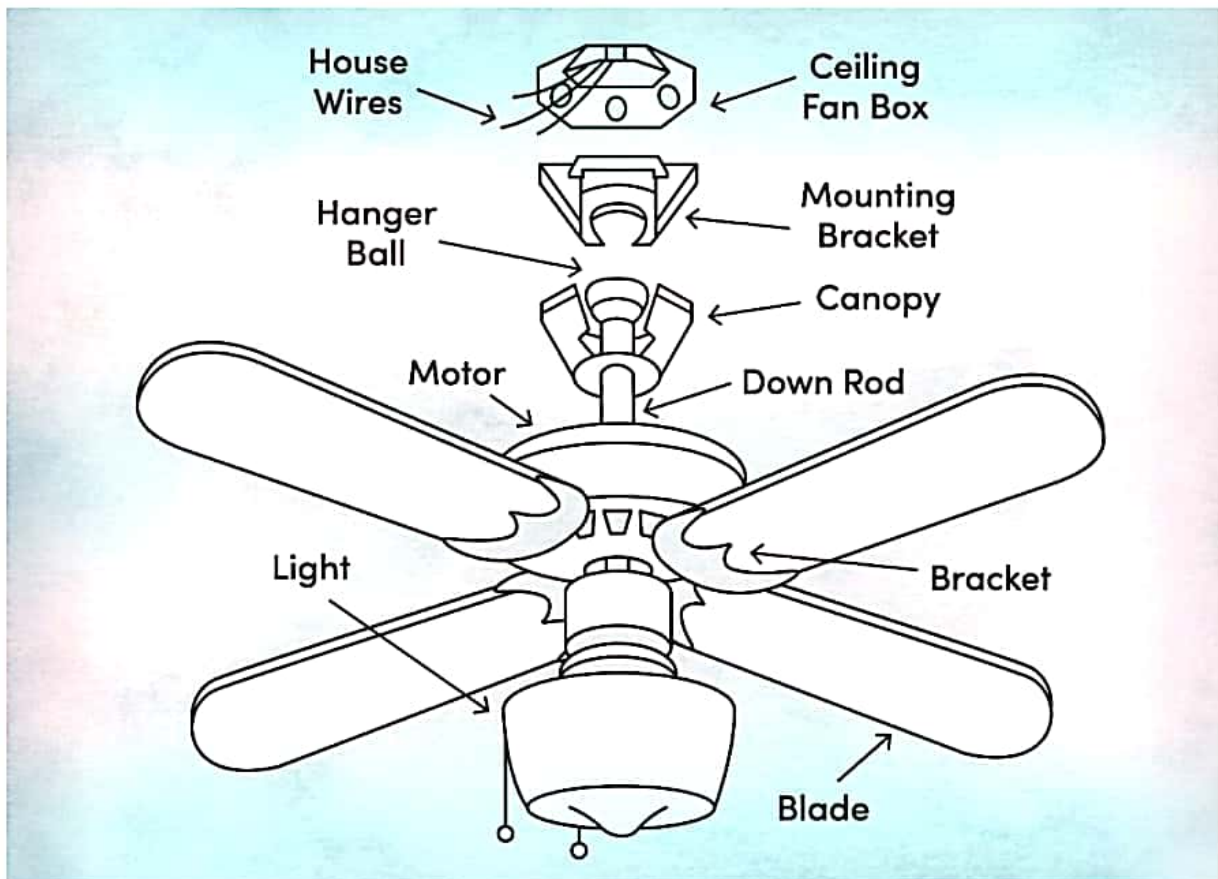

CIRCUIT DIAGRAM-

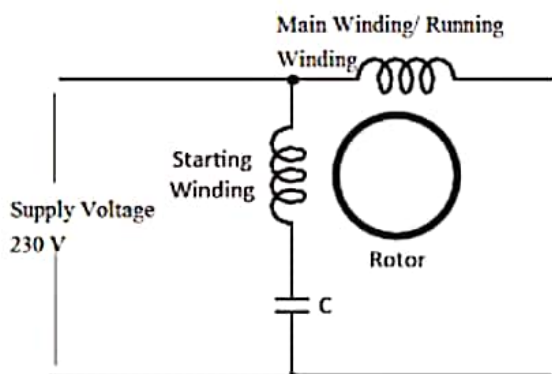

CONCLUSION:-

DISCUSSION QUESTION

- I. What is S.W.G? Draw a neat diagram.
- II. What is Auxillary Winding?
- III. What is Main Winding?
- IV. What is Ferrari' s Principle?
- V. Why 1phase I.M are not self starting?

EXPERIMENT NO: -07

AIM OF THE EXPERIMENT: -

Find out fault of DC generator, repair and test it to run.

EQUIPMENT REQUIRED: -

Sl.no	Name	Specification	Quantity
1	Dc generator	1Ø230v,50Hz,60W	1no
2	Insulated Plier	15cm insulated	2no
3	Screw Driver	15cm	2no

THEORY: -

An electrical machine is a mechanical device which converts mechanical energy in to electrical energy. The energy conversion based on the principle of production of dynamically induced emf. A production machine consists of the following essential parts.

PARTS OF A DC MACHINE: -

1. Pole core or pole shoe.
2. Magnetic frame or yoke.
3. Pole coils or field coils.
4. Armature core.
5. Armature winding or conductor.
6. Commutator.

7. Brushes

DC GENERATOR

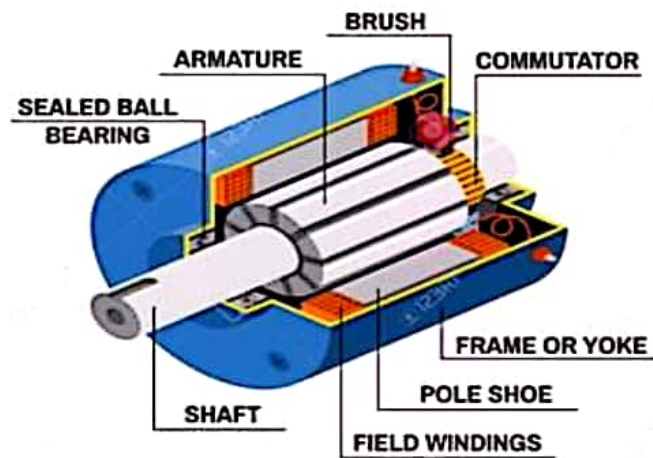

**FAULT
DC
GENERATOR:-**

FINDING OF

A. Generator fails to build up voltage:

SL.NO	Reason	Remedies
1.	Direction of rotation reverse.	Change the direction of rotation(D.O.R)
2.	No residual magnetism	Recharge the poles by the help of battery or DC source.
3.	Open circuit in armature.	Check the armature winding circuit.
4.	Open circuit in field winding.	Check the field winding circuit.
5.	Short circuit in field winding .	Check the field winding circuit.
6.	Brushes contact not proper with commutator.	Keep the brushes at M.N.A. and contact should be proper.

B. Generator having heavy sparking at commutator:

SL NO	Reason	Remedies
-------	--------	----------

1.	Brushes are not a M.N.A. position.	Set the brushes at M.N.A. position as per generator direction of rotation.
2.	Not proper spring tension on brushes.	Check and set the spring tension.
3.	Carbon or dust on the surface of commutator.	Clean the commutator with fine sand paper.
4.	Commutator surface is not proper.	Check and get it proper on the lathe machine .
5.	Cross in armature winding.	Check the armature winding and remove the fault.
6.	Wrong connection of inter poles	Check the direction of inter poles .It should be the same in the case of generator and opposite in case of motor with respect to main poles. Check the mica surface between two segments and sets its surface properly.
7.	Mica is not properly placed .	Check the size and grade of brushes .
8.	Brushes are not of proper size and grade.	

C.Generator produce more heat and sound

SL NO	Reason	Remedies
1.	Defective bearings.	Check and lubricate the bearings or replace the bearing.
2.	More load on armature.	Reduce the load.
3.	Improper fitting on the end covers.	Fit the bearings in covers properly and tight the screws.
4.	More sparking .	Check the reason explained in the above table.
5.	Not properly fixed .	Check the foundation nut bolts.

Finally , to minimise failures , regular preventative maintenance inspections and takes should be carried out. Power supply circuitry should include overload protection to remove transient voltage spikes.

CONCLUSION: -

DISCUSSION QUESTION: -

1. What is DC generator?
2. What are the effects of armature reaction?
3. Write down main parts of DC generator?
4. Why the armature is laminated? 5. What are types of dc generator?

EXPERIMENT NO.8

AIM OF THE EXPERIMENT: -

FIND OUT FAULT OF D.C. MOTOR STARTER AND A.C. MOTOR STARTER ☐ PREPARE AN INVENTORY LIST OF PARTS USED IN DIFFERENT STARTER.

APPARATUS REQUIRED: -

FAULT FINDING AND SOLUTION OF AC MOTOR WITH A STARTER-

PROBLEM	POSSIBLE CASUE	TESTS	SOLUTION
Motor will not start.	<ol style="list-style-type: none"> 1. Fault with supply_ 2. Motor or load locked up. 3. Wrong connections in control circuit. 	<ol style="list-style-type: none"> 1. Check for correct voltage at motor terminal. 2. Make sure motor and load are free to turn. 3. Check to ensure contactors operate. 	<ol style="list-style-type: none"> 1. Fit news fuse, reset circuit breakers, etc. 2. Remove clamps, locks, etc. 3. Sort out control circuit.
Supply or started trips out at start.	<ol style="list-style-type: none"> 1. Wrong or loose connections. 2. Motor overload. 3. Intertie of load to high. 4. Low voltage due to volt drop in cable. 5. Overload or circuit breaker incorrectly set or sized.3 	<ol style="list-style-type: none"> 1. Check all lugs are properly crimped or soldered, and connections are tight. 2. Check load performance data. 3. Measure voltage at motor terminals while motor starting. 4. Check setting of overload and circuit breaker and allow for starting current. 	<ol style="list-style-type: none"> 1. Fix up connections. 2. Change motor for correct size. 3. Change cable for correct size. 4. Correct setting of overload or breaker or change.
<p>Motor starts but has no torque.</p> <p>Motor does not reach full speed or takes a long time to accelerate.</p>	<ol style="list-style-type: none"> 1. Incorrect connection. 2. Delta wound motor connect in star. 3. Star/delta starter staying in star. 4. Intertie of load to high. 5. Motor overloaded. 6. Low voltage due to volt drop in cables. 	<ol style="list-style-type: none"> 1. Check connection diagram and nameplate data. 2. Check load. 3. Measure voltage at motor terminals while motor starting. 	<ol style="list-style-type: none"> 1. Sort out and correct connections. 2. Check timer and starter control circuit. 3. Change motor for correct size. 4. Change cables for correct size.

Motor overheating.	<ol style="list-style-type: none"> 1. Motor overloaded. 2. Ineffective cooling. 3. Excessive ambient. 4. Wrong connection. 5. Delta wound motor in star. 6. Wrong single phasing. 7. Wrong voltage or frequency. 8. Supply voltage unbalanced. 	<ol style="list-style-type: none"> 1. Check load performance data. 2. Check fan and air flow and temperature of air. Look for build-up of dirt. 3. Check connection diagram nameplate data. 4. Check volt and amps in all three phase. 5. Check nameplate. 	<ol style="list-style-type: none"> 1. Fix problem load or fit large motor. 2. Clean motor. Sort out cooling of air temp. and flow. 3. Sort out connections. 4. Restore supply to all phase. 5. Correct voltage frequency. Balance supply or accept unbalance.
No load amps in excess of full load amps.	<ol style="list-style-type: none"> 1. Incorrect connection 2. Star wound motor connection delta 3. voltage in excess of nameplate. 4. Motor supplied for different voltage or frequency. 	<ol style="list-style-type: none"> 1 & 2 . check connection diagram and nameplate data. 3. measure voltage at motor terminals. 4. compare supply voltage and frequency to nameplate. 	<ol style="list-style-type: none"> 1 & 2. Sort out and correct connections at motor terminals. 3. correct supply voltage. 4. change motor for correct voltage and frequency.
<p>Mechanical noise or vibration.</p> <p>Noisy bearings.</p> <p>Bearings overheating.</p>	<ol style="list-style-type: none"> 1. Trust from load or misalignment. 2. Damaged bearings too much grease, no grease, or foreign matter in grease. 3. Rotor pulling or foreign matter in air gap. 4. Out of balance load, coupling or pulley. 5. Excessive belt pull. 	<ol style="list-style-type: none"> 1. Check gap between coupling halves and alignment. 2&3 .turn shaft slowly by hand feel for roughness or stiffness. Check for bent shaft or fan rubbing. 4. run motor disconnected from load and then with pulley or coupling removed removed. 5. run motor without belts. 	<ol style="list-style-type: none"> 1. Re-align couplings 2&3. Clean bearing housing, change bearings and repack with fresh grease. 4. fix up out of balance items. 5. loosen belt tension.

	6. Motor foundations not rigid.	6. check design and constructions foundations.	6. increase strength of foundations.
Motor amps in excess of nameplate full load amps on load.	<ol style="list-style-type: none"> 1. Motor overload. 2. Low supply voltage. 3. Wrong voltage or frequency. 4. Wrong connection. 5. Motor ☐ single phasing☐. 6. Supply voltage unbalanced. 7. Motor speed not match to load. 	<ol style="list-style-type: none"> 1. Check load and performance data. 2. Measure voltage at motor terminals. 3. Check nameplate. 4. Check nameplate 5&6. Check volts and amps in all three phase. 7. measure motor speed and check load speed requirements. 	<ol style="list-style-type: none"> 1. Fix problem with load or fit larger motor. 2. Fix problem, maybe with larger cables. 3. Correct voltage or frequency. 4. Sort out and correct. 5&6. Restore balanced supply to all three phase. 7. change motor for correct motor speed.
Excessive electric noise.	<ol style="list-style-type: none"> 1. Wrong connection 2. Wrong voltage. 3. Motor ☐single phase☐. 	<ol style="list-style-type: none"> 1. Check connections. 2. Check voltage with nameplate. 3. Check volts with amps in all three accurately. 	<ol style="list-style-type: none"> 1. Fix up connections. 2. Correct voltage. 3. Restore supply to all three phase.
Unbalanced amps in different phase when motor loaded.	<ol style="list-style-type: none"> 1. Unbalanced supplying voltage. 	<ol style="list-style-type: none"> 1. Measure phase to phase voltage accurately 	<ol style="list-style-type: none"> 1. Balance supply or accept unbalanced.
Motor runs in wrong direction.	<ol style="list-style-type: none"> 1. Wrong connections. 	<ol style="list-style-type: none"> 1. Watch shaft rotation. 	<ol style="list-style-type: none"> 1. Swop two phase of supply.

DIFFERENT PARTS AND AC MOTOR AND STARTER-

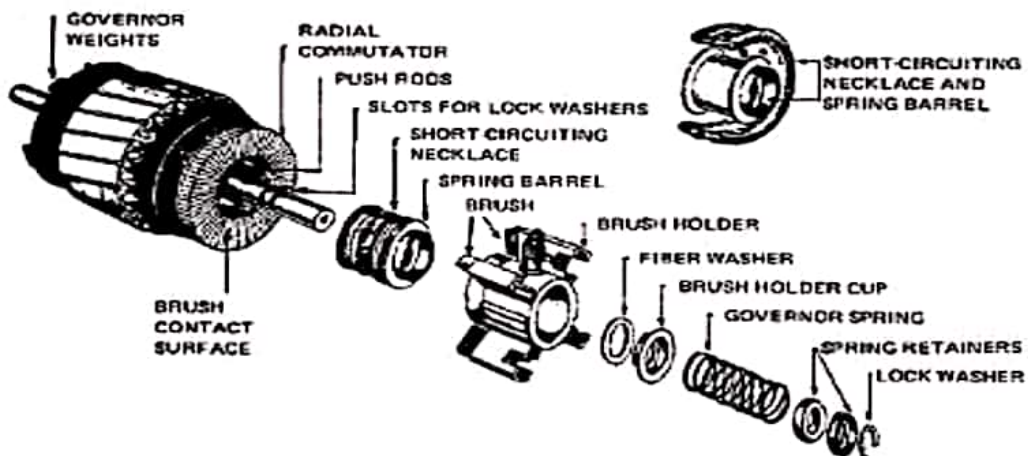
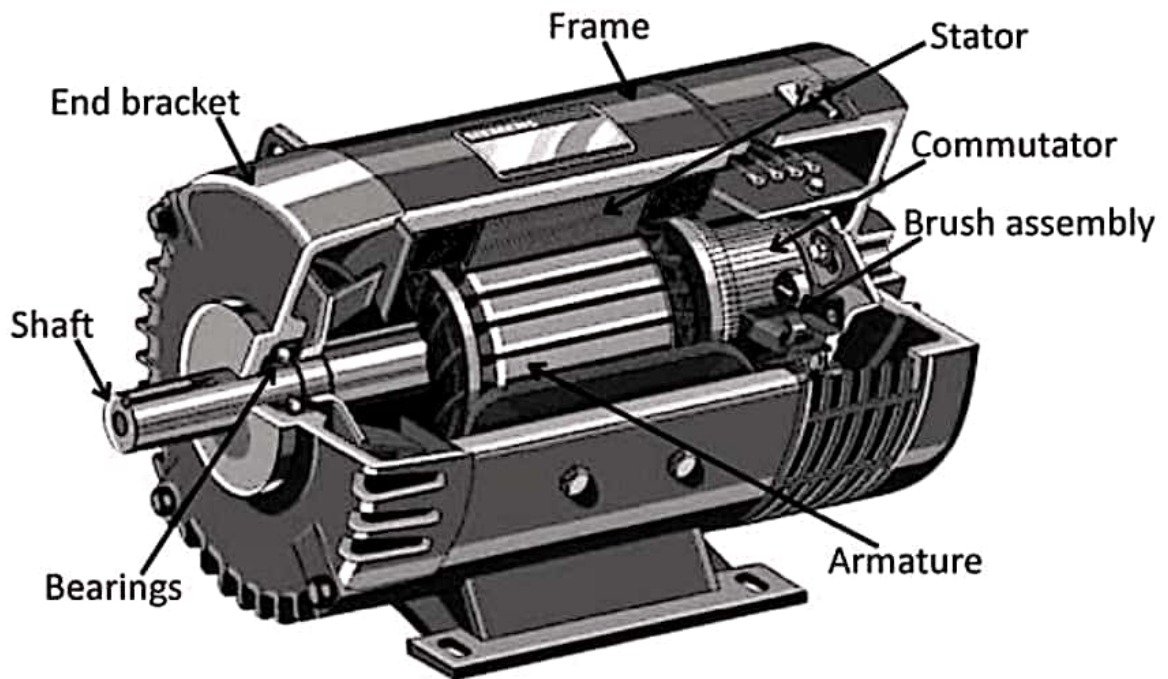

COMPONENTS OF D.O.L. STARTER :

Overload Unit (Thermal type)

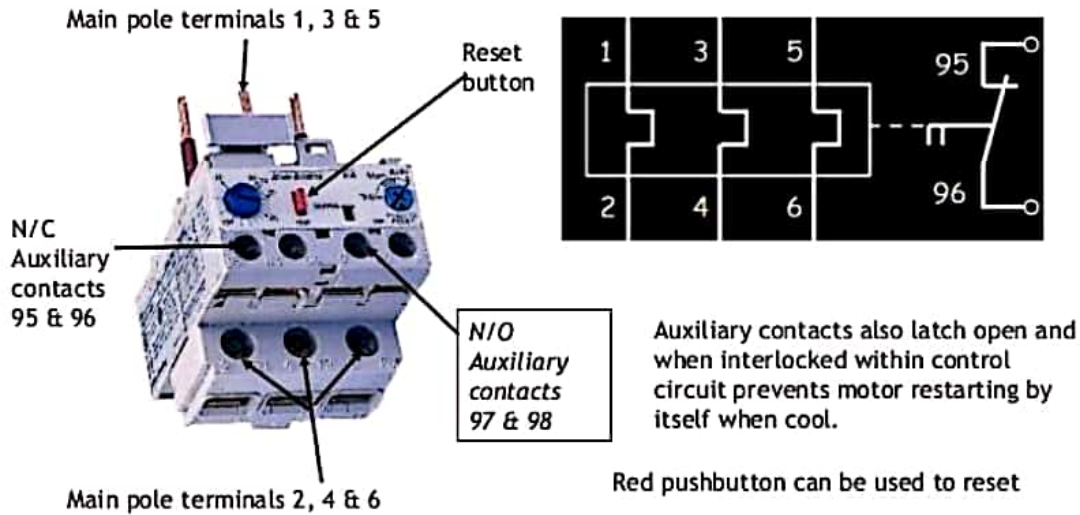

FAULT FINDING AND SOLUTION OF DC MOTOR WITH A STARTER.

PROBLEM	CAUSES	REMEDIES
Motor fails to start.	<ol style="list-style-type: none"> 1. Main supply off. 2. The brushes are not making good contact with the commutator. 3. Open circuit in armature or in field winding. 4. There may be break in wiring or cable. 5. There may be break in starter resistance. 	<ol style="list-style-type: none"> 1. Test supply or fuse with test lamp. 2. Clean the commutator with sand-paper and set the brushes to exert pressure and make good contact. 3. Test the armature and field windings with a test lamp.

		<p>4. Test the continuity of the ending from main switch to motor.</p> <p>5. Test the starter.</p>
Motor gives shock	<ol style="list-style-type: none"> 1. Armature of field coils or brush holder may be earthed. 2. The body of the motor is not properly earthed. 	<ol style="list-style-type: none"> 1. Test the insulation of rocker arm. Tight the earth wire 2. Test the earth wire if it is loose, tight it.
Motor blows fuse at start	<ol style="list-style-type: none"> 1. The capacity of the fuse is small as compared to load. 2. Over load. 3. Body of the machine may be earthed. 4. Short circuit in the starter resistance. 5. Wrong starting and moving the handle very quickly. 	<ol style="list-style-type: none"> 1. Replace fuse with proper size. 2. Reduce the load. 3. Trace the earth by megger or test lamp and insulate it. 4. Check the starter resistance and remove the defect. 5. Start the motor properly by slowly moving the handle.
Motor runs at a very high speed	<ol style="list-style-type: none"> 1. No load (in case series motor) 2. Motor may be different compound. 3. Open circuit is in no coil. 4. Supply voltage is too high. 5. The field regulator of shunt field may be completely in 'ON' position. 	<ol style="list-style-type: none"> 1. Put the load on motor before starting. 2. Check and reverse the direct of current in series field. 3. Test the continuity with test lamp or megger. 4. Check supply voltage, if it is possible reduce the voltage. 5. Adjust the regulator to the OFF position at the time of starting.
Low speed than rated speed	<ol style="list-style-type: none"> 1. Low voltage. 2. Bearing may be loose. 3. Excessive load on the motor. 4. Short circuit or earth in the armature. 	<ol style="list-style-type: none"> 1. Check the supply voltage and start the motor according to its rated voltage. 2. Replace the bearing. 3. Reduce the load. 4. Rest polarity of main poles with a compass needle and connect them alternating 'N' and 'S'. 5. Test the armature and remove the fault.
Sparking on the brushes	<ol style="list-style-type: none"> 1. Commutator surface is not round and smooth. 2. Commutator is dirty. 3. Mica level above the commutator segment. 4. Loose contact of brushes with the commutator. 	<ol style="list-style-type: none"> 1. trun commutator on lathe and also clean with sand-paper. 2. Clean the commutator with sand-paper Or petrol. 3. Cut down the mica 1/10 below the commutator with a fine saw.

	<ul style="list-style-type: none"> 5. Brushes holder are loose. 6. Short circuit in commutator. 7. Brushes are not in the neutral axis. 8. Wrong inter pole polarity. 9. Over load on the motor. 10. Poor grade of brushes. 	<ul style="list-style-type: none"> 4. Adjust the spring tension. 5. Tighten the brushes properly. 6. Adjust brushes position. 7. Reduce load.
Sound in the motor	<ul style="list-style-type: none"> 1. Loose fitting of foundation. 2. Loose field poles to the yoke. 3. Sound from brushes. 4. Loose bolts of side covers. 5. Defective bearing. 	<ul style="list-style-type: none"> 1. Tight the nut bolt of the foundation. 2. Tight the field poles. 3. Check the armature shaft on lathe. 4. machine and get the fault rectified. 5. Apply a little gasoline on the brushes. 6. Tight the nut bolts. 7. Check and replace if necessary.
Overheating	<ul style="list-style-type: none"> 1. Short circuit in the windings. 2. Faulty or dirty bearings. 3. Overload on motor. 4. Due to sparking at the commutator. 	<ul style="list-style-type: none"> 1. Test the winding and remove the fault. 2. Wash it properly. 3. Reduce the load. 4. Remove the cause and reduce the sparking.

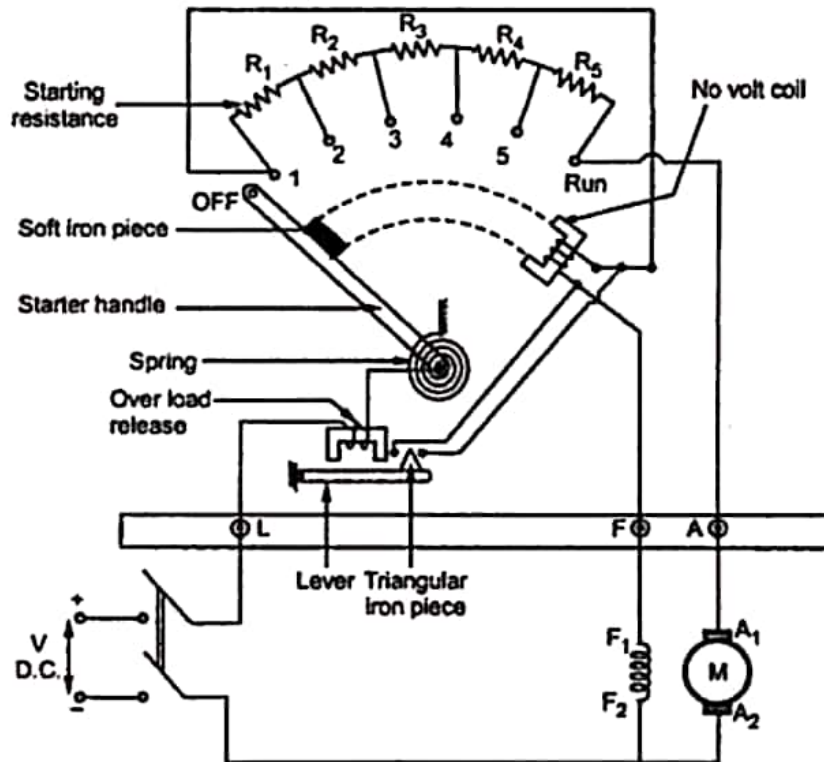

3 point Starter

Conclusion-

DISCUSSION QUESTION.

1. What is crawling ?
2. What is cogging ?
3. What is plugging ?
4. What is NVR ?
5. What is OLR ?

EXPERIMENT-9

AIM OF THE EXPERIMENT:

Use crimping tools to lug sockets on L.T and H.T aluminium cable from 10 mm² to 50mm².

APPARATUS REQUIRED:

SI.NO.	Name of the equipment	specification	Quantity
1.	Compression tool	VIRAT,0.5mm to 6mm ² ,weight-350gm.	1no.
2.	Aluminium cable	5mm ² -10mm ²	As per required.

THEORY:

Crimping is joining two or more pieces of metal or other ductile material by deforming one or both of them to hold other. the bent or deformity is called the crimp.

to use this crimping tools each wire is frist placed into the connector.Once all the wires are in the jack,the connector with wires is placed into the crimping tool and the handles are squeezed together.

crimping punctures the plastic connector and holds each of the wires,allowing for data to be transmited through the connector.

crimping tools are are of different types such as 0.14mm to 10mm. insulated and non insulated type and RJ-11,RJ-6,RJ-14 etc common type crimping tool is RJ-11.

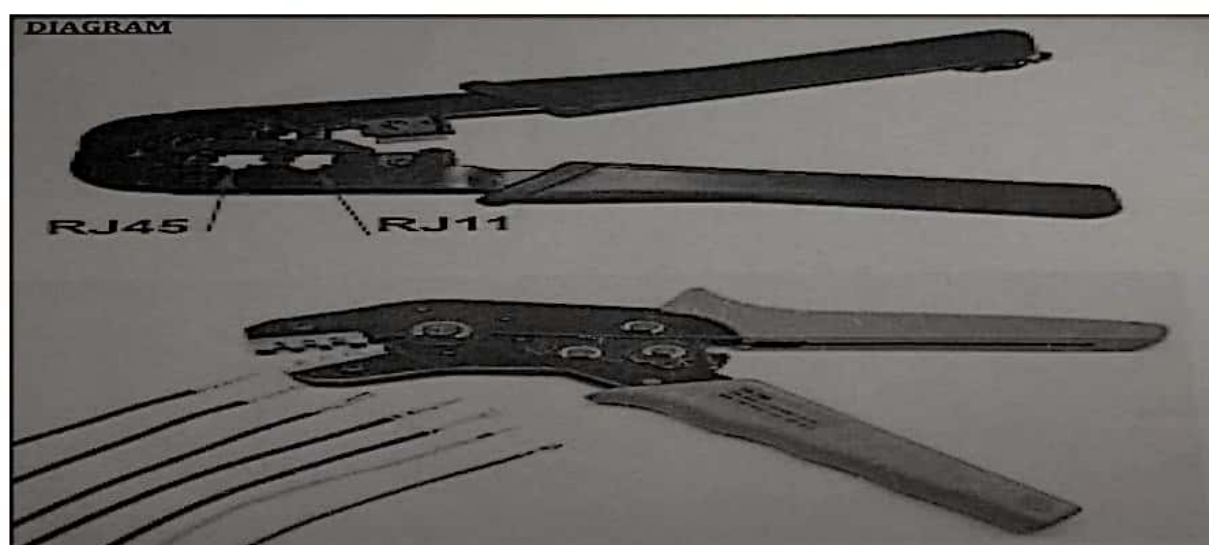

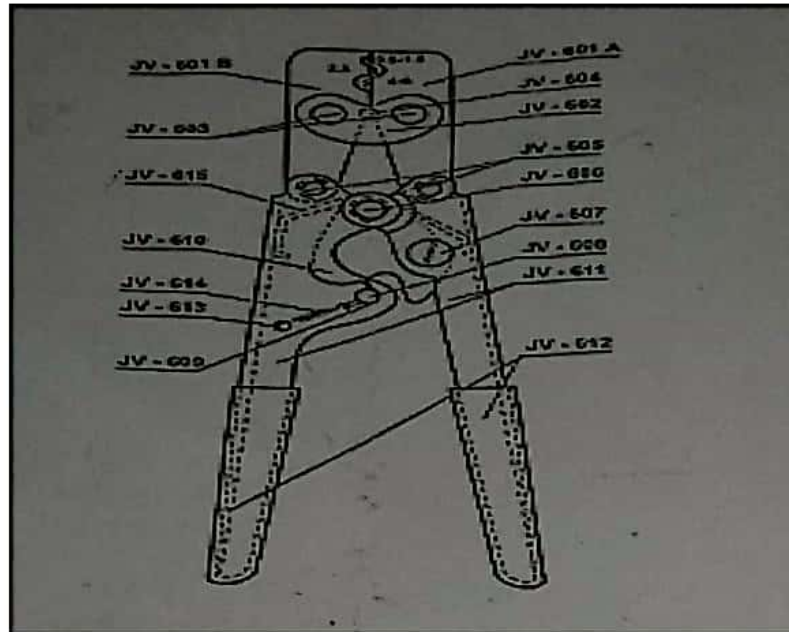

PART-LIST

PART No.	Description	Quantity
JV-601A	Die Jaw	1
JV-601B	Die Jaw	1
JV-602	Support for Jaw	2
JV-603	Rebit Pin	2
JV-604	Roller for jaw	1
JV-605	Pin for jaw	2
JV-606	Pivot Pin	1
JV-607	Eccentric Pin	1
JV-608	Pin For Latch	1
JV-609	Latch(Dog)	1
JV-610	Ratchet	1
JV-611	Handles	2
JV-612	Hand Grips	2
JV-613	Spring Dowel Pin	1

JV-614	Spring	1
JV-615	Spring	1

CONCLUSION: -

DISCUSSION QUESTIONS:

1. What is crimping?
2. what is manual crimping tools?
3. what are wire crimps?
4. How do you use a wire crimping tool?
5. what is an F crimp?

EXPERIMENT NO: -10

AIM OF THE EXPERIMENT: -

Dismantle, over haul and assemble a single phase induction motor, Test and run it prepare an inventory list.

EQUIPMENT REQUIRED: -

SL NO.	NAME OF EQUIPMENT	SPECIFICATION	QUANTITY
1	1 Phase induction motor	400v,20hp,50hz	1no.
2	Series lamp	100Watt	1nos.
3	Multimeter	Digital	1nos.
4	Neon Tester	0-500v	1no.
5	c-plier	Insulated-15cm	1no.
6	Screw Driver	Insulated-15cm	1no.
7	Spanner	TAPARIA	1no.
8	E Knife	Insulated-15cm	1no.
9	Insulation Tape	PVC type	1no.
10	Connecting Wire	2.5 mm copper	As per required

THEORY: -

some physical task, this induction motor requires only one power phase for their proper operation. they are commonly used in low power application, in domestic and industrial use, simple construction, cheap cost, better reliability, eases to repair and better maintenance are some of its Marable advantage

Construction of single phase induction motor:

The main components of the Single Phase induction motor are stator and rotor. Stator is known to be the stationary Single phase induction motor is an AC motor were electrical energy is converted to mechanical energy to perform part. Usually, the single phase alternating supply is given to the stator winding. Rotor is the rotating part of the motor. Rotor is connected to the mechanical load with the help of a shaft. A squirrel cage rotor is used here. It has a laminated iron core with many slots. Rotor slots are closed or semi-closed type. The rotor windings are symmetrical and at the same type it is short circuited. An air gap is there between the rotor and the stator. The most practical applications of this

motor are in refrigerators, clocks, drills, pumps, washing machines etc. The stator winding in the 1ϕ induction motor has two parts: Main Winding and Auxiliary Winding. Usually, the Auxiliary winding is perpendicular to the main winding. In 1ϕ induction motor the winding with more turns is known as main winding. While the other wire is called as auxiliary winding.

Principle of operation of 1 phase induction motor:

A Single Phase Induction Motor consists of a single phase winding which is mounted on the stator of the motor and a cage winding placed on the rotor. A pulsating magnetic field is produced, when the stator winding of the single-phase induction motor shown below is energized by a single phase supply. The word Pulsating means that the field builds up in one direction, falls to zero and then builds up in the opposite direction. Under these conditions, the rotor of an induction motor does not rotate. Hence, a single phase induction motor is not self-starting. It requires some special starting means. If the 1 phase stator winding is excited and the rotor of the motor is rotated by an auxiliary means and the starting device is then removed, the motor continues to rotate in the direction in which it is started. The performance of the single phase induction motor is analyzed by the two theories. One is known as the Double Revolving Field Theory, and the other is Cross Field Theory. Both the theories are similar and explain the reason for the production of torque when the rotor is rotating.

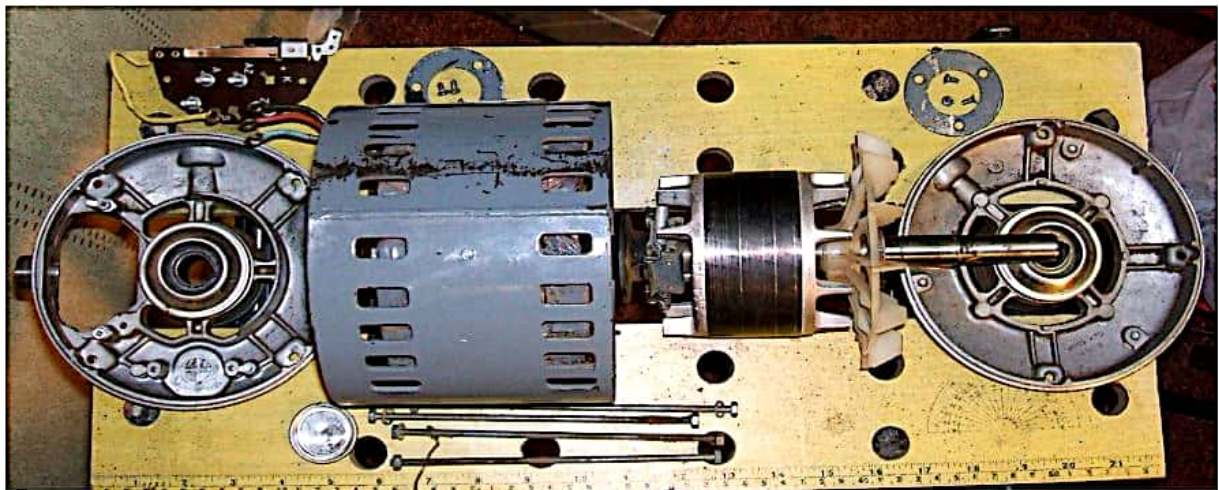

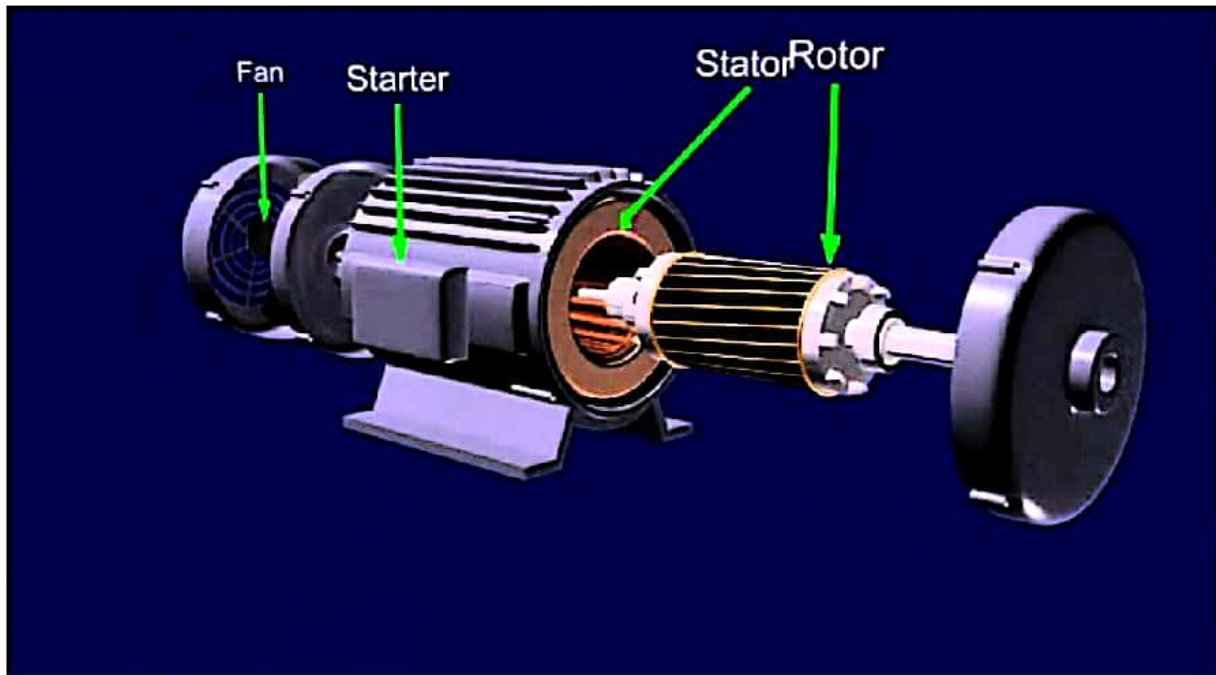

Dismantle of 1phase induction motor

STEPS OF DISMANTLING OF 1 PHASE I.M: -

- *First of all remove the pulley of motor on the shaft, also remove the cooling fan of the motor then open the screwed on the shaft of the motor.
- *The shaft or pulley of the motor is always in front of your eyes and then you mark a line on the cover and yoke, the advantage of the line is that when you closing the motor easily meet the mark point & easily cover the motor
- *open the nut-bolt, screw of the end cover of the motor by using spanner or screw driver.
- *Two screw driver are inserted in motor cover and apply a little pressure internally as a result, the cover of the motor is easily opened
- *After that the rotor of the motor easily come out
- *The bearing of the motor is dip in to kerosene, oil and then apply grease into the bearing.
- *clean the stator of the motor carefully

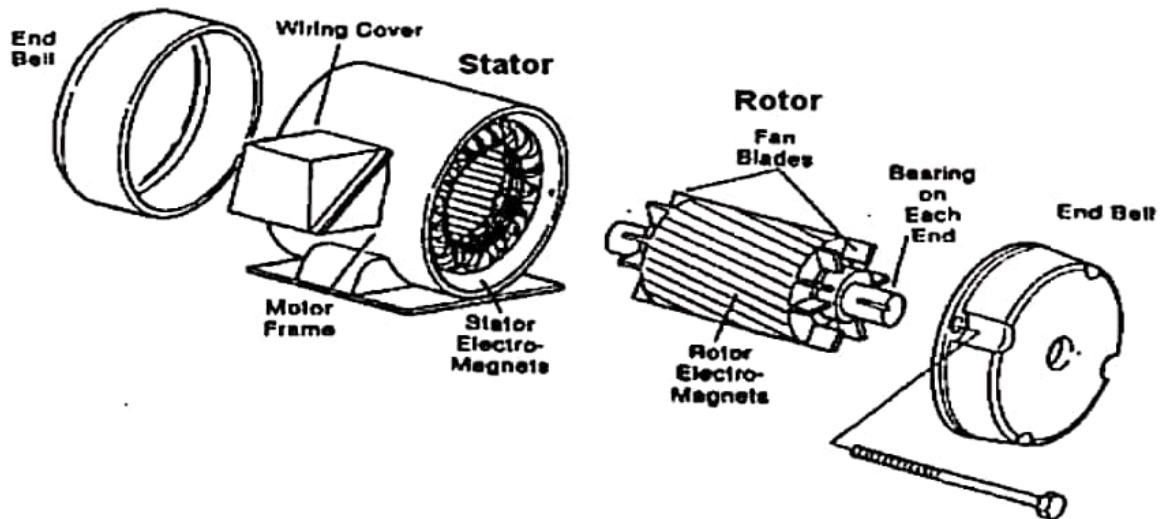

STEPS OF ASSEMBLING OF 1 PHASE I.M: -

- *First of all, the end cover of the motor is screw with the yoke
- *Enter the rotor of the motor in stator
- *Fit the rotor in exact position in stator and then screwed the front cover of the motor
- *The cooling fan of the motor is screw on the shaft
- *in last tight the cover of the cooling fan with the yoke of the motor

STEPS OVER HAULING OF 1 PHASE I.M:-

The 1 phase induction motor can over hauling following manner-

***INSULATION TEST-**

Checking the insulation of the stator winding is very important before and after the overhaul procedure. Multimeter is used for this purpose, with its one probe connected to the winding and other to the earth with switch selected in the resistance knob.

***DISMANTLING-**

Note: Before dismantling any part of the motor or motor connection, marking of both motor housing and connection wires is very important. This will ensure that the boxing back procedure is smooth and there is no mismatch of parts. Also check the direction of the motor rotation before stopping the motor for overhauling.

Before overhauling the motor, pre-planning of removing and fixing back the motor safely in place must be discussed and implemented (depends on place where it's fixed and also on the size of the motor) otherwise the load side (for e.g. Pump connected to motor) will be damaged

by the motor shaft. The motor can be connected to the load as vertically coupled load and horizontally coupled load. Horizontally coupled having two types:

1. Hinge mounted (Must be done very carefully)
2. Base mounted

Above the processes are completed, perform the following procedure:

1. Removal of Bearing Housing Cover:-

While removing the bearing housing cover, note that some motors will be having inner bearing cover tightened with nut bolts. Remove it carefully. In other constructions the bearing housing cover is locked with bearing by a circle clip. Whenever removing the housing cover on both sides (Driving End & Non Driving End) make sure proper care is taken while handling.

2. Removal of bearing and coupling:-

Use a suitable puller (depends on the size of the bearing or coupling); mostly use the 3 arm puller as it has a good pulling strength.

First use the puller by barely applying any pressure and try to take out the bearing or coupling,

*If it's not coming out even after enough load, use a pipe and extend the tightening spanner and try to remove the bearing

*If the bearing is still stuck at the original position, heat the bearing or coupling up to 100 deg. C while it's locked with the puller and apply little pressure

*If the bearing or coupling is not coming out with the above tricks, the last method is to apply the load on puller through hydraulic jack along with heating

*After opening the stator cover, thoroughly inspect the inside condition of the stator. If there is little damage in rotor, repair it

*If the insulation of the motor is less, clean the windings by an evaporative type cleaner and give sometime to let it dry. Apply insulation coating and heat the winding around 40 deg. C to 50 deg. C by means of powerful halogen lamps

*Clean both side bearing housing covers, cooling fan, body of the motor and protection cover of the motor with electro clean or suitable chemical

3. Ins Clean the shaft on both ends and heat the new bearing up to 70 deg. C to avoid tight insertion of the bearing in the shaft. Do this for both sides. Wait for 20 minutes, let the bearing cool down, and after that insert the bearing housing cover from one side.

4. Box back the motor:-

Before boxing up the motor, do the insulation test again to compare with previous values. If the values are on higher side, start boxing back, otherwise heat up the winding for some more

time with Halogen light.Box up to be done as per the markings Take up the rotor with one side cover (If bearing locking nut were there in one of the sides, prefer that to be the first to assemble) and push it inside the stator Lock with one side nut bolts, slowly insert the other side cover, do the hammering slowly by wooden hammer, insert and lock with nut and bolts, and the rotor will now apply load on the bearing Gently tighten the bolts using opposite tightening method. Insert the cooling fan and protection cover, and once again verify the tightness of the bolts Fix in place the motor as per the marking and give the connections accordingly.Try out and check the Amperage. Compare with rated amperage and before overhaul amperage. *Note: Check the direction of rotation after overhauling. If it indicates opposite direction, it means the connection done is wrong.

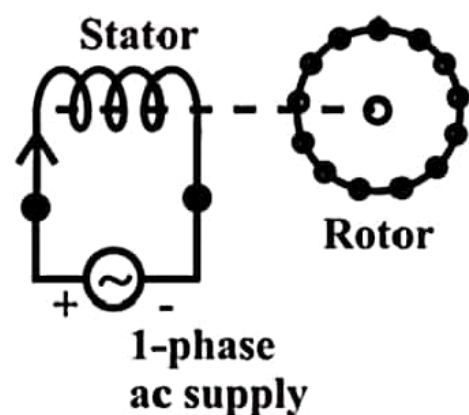
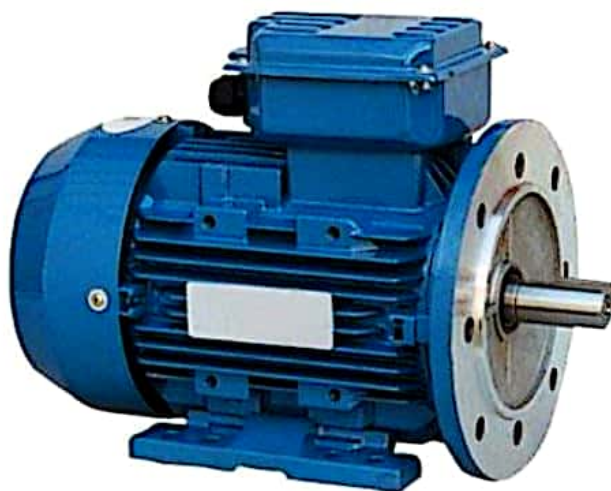

SAFETY&PRECAUTION:-

- *All the connection should correct & tight.
- *Before working on machine Follow safety rule.

CONCLUSION: -

In the above experiment we perform Dismantle, over haul and assemble a single phase induction motor.

DISCUSSION QUESTION: -

1. State difference between induction motor & squirrel cage motor?
2. Application of induction motor?
3. Write Application of phase wound motor.
4. What type of test perform when the motor is in damaged state?

EXPERIMENT NO :11

Aim of the experiment :

Dismantle over haul and assemble a 3 phase squirrel cage and phase wound motor . Test and run them.

Equipment Required:

SL no.	Name of the equipment	Specification	Quantity
1.	3phase squirrel cage motor	,20Hp,400v,50Hz	1
2.	Phase wound motor	,400v,50Hz	1
3.	Series lamp		1
4.	Multimeter	Digital	1
5.	Tester	0-500v	1
6.	C-plier	Insulated ,15cm	1
7.	Screw driver	Insulated,15cm	1
8.	E knife	Insulated ,15cm	1
9.	Connecting wire	2.5 mm cu.	As per required

Theory :

A 3 phase squirrel cage induction motor is a type of 3 phase induction motor which functions based on the principle of electromagnetism. It is called a squirrel cage motor because the rotor inside it looks like a squirrel cage . This type of induction motor are widely used in industrial applications due to cheaper in cost , rugged in construction and low maintenance .

A phase wound induction motor is also known as slip ring rotor motor,iris a type of induction motor where the rotor windings are connected through slip rings to external resistance . Adjusting the resistance allows control of the speed /torque characteristic of the motor . This type of motor is used in applications which require smooth start and adjustable speed . Some of the applications of

this motor include cranes ,mills and conveyors. The phase wound motor is used I fans , blowers and mixer etc .

Circuit diagram:

3phase squirrel cage motor :-

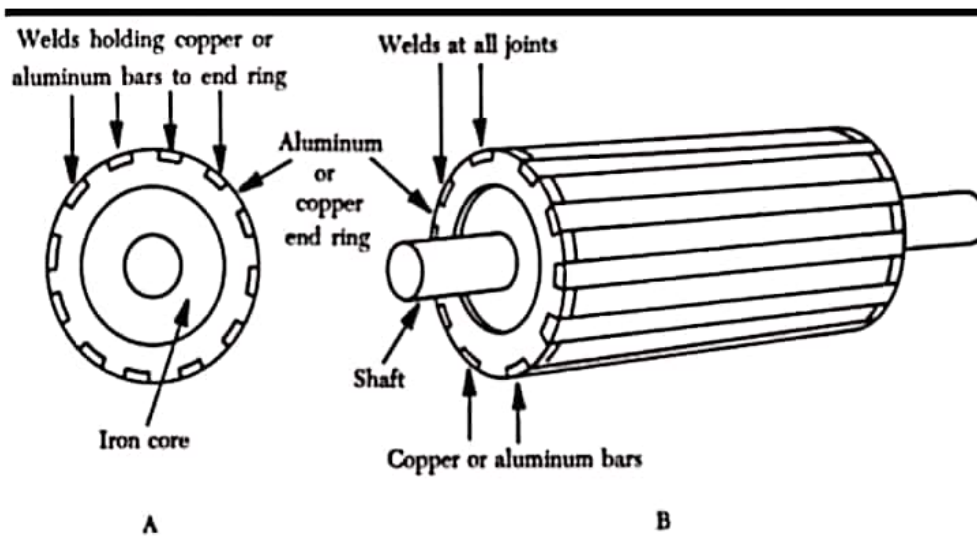

Phase wound motor:-

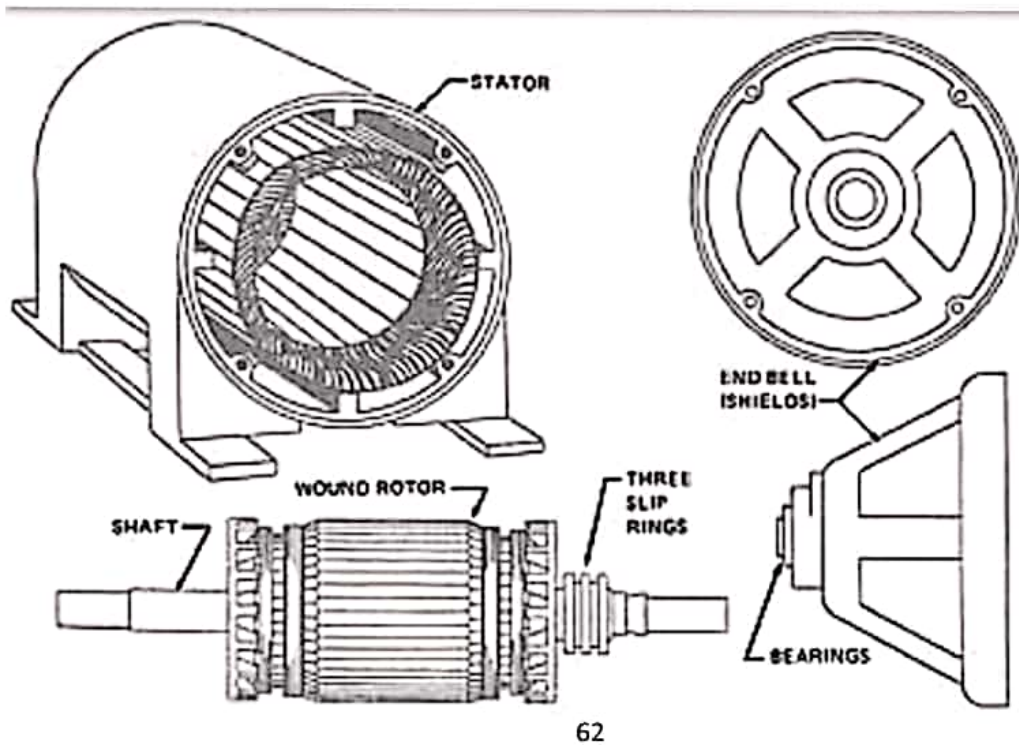

Working Procedure:

- Take out the motor from the place and keep it in a horizontal position
- Open the motor from any one side
- If it' s a small motor take out the rotor
- If it' s a huge motor keep the rotor inside and open the bearings using a good bearing puller

Safety precautions:

- All the connections should be perfect and tight .
- Assembly all the parts correctly.

Conclusions:

Discussion Questions:

- 1.what is the difference between squirrel cage and phase wound motor?
- 2.write the application of phase wound motor.
- 3.write the application of squirrel cage motor .

EXPERIMENT NO-12

AIM OF THE EXPERIMENT: -

Overhaul of single phase / 3 phase variac.

APPARATUS REQUIRED: -

SL.NO	NAME OF EQUIPMENTS	SPECIFICATION	QUANTITY
1	Single phase variac	1 phase,10A,2.7KVA,230V,50Hz	1no
2	3 phase variac	3 phase,15A,12.8KVA,415V,50Hz	1 no

THEORY

CONSTRUCTION

An autotransformer is an electrical transformer with only one winding. The "auto" (Greek for "self") prefix refers to the single coil acting alone, not to any kind of automatic mechanism. In an autotransformer, portions of the same winding act as both the primary winding and secondary winding sides of the transformer. In contrast, an ordinary transformer has separate primary and secondary windings which are not connected to each other.

The autotransformer winding has at least three taps where electrical connections are made. Since part of the winding does "double duty", autotransformers have the advantages of often being smaller, lighter, and cheaper than typical dual-winding transformers, but the disadvantage of not providing electrical isolation between primary and secondary circuits. Other advantages of autotransformers include lower leakage reactance, lower losses, lower excitation current, and increased VA rating for a given size and mass.

PRINCIPLE:-

An autotransformer has a single winding with two end terminals and one or more terminals at intermediate tap points. It is a transformer in which the primary and secondary coils have part of their turns in common. The primary voltage is applied across two of the terminals, and the secondary voltage taken from two terminals, almost always having one terminal in common with the primary voltage. Since the volts-per-turn is the same in both windings, each develops a voltage in proportion to its number of turns. In an autotransformer, part of the current flows directly from the input to the output, and only part is transferred inductively, allowing a smaller, lighter, cheaper core to be used as well as requiring only a single winding.[3] However the voltage and current ratio of autotransformers can be formulated the same as other two-winding transformers.

One end of the winding is usually connected in common to both the voltage source and the electrical load. The other end of the source and load are connected to taps along the winding. Different taps on the winding correspond to different voltages, measured from the common end. In a step-down transformer the source is usually connected across the entire winding while the load is connected by a tap across only a portion of the winding. In a step-up transformer, conversely, the load is attached across the full winding while the source is connected to a tap across a portion of the winding.

DIAGRAM OF SINGLE PHASE VARRIAC:-

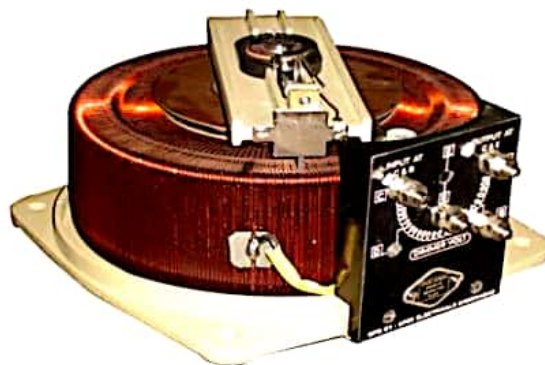
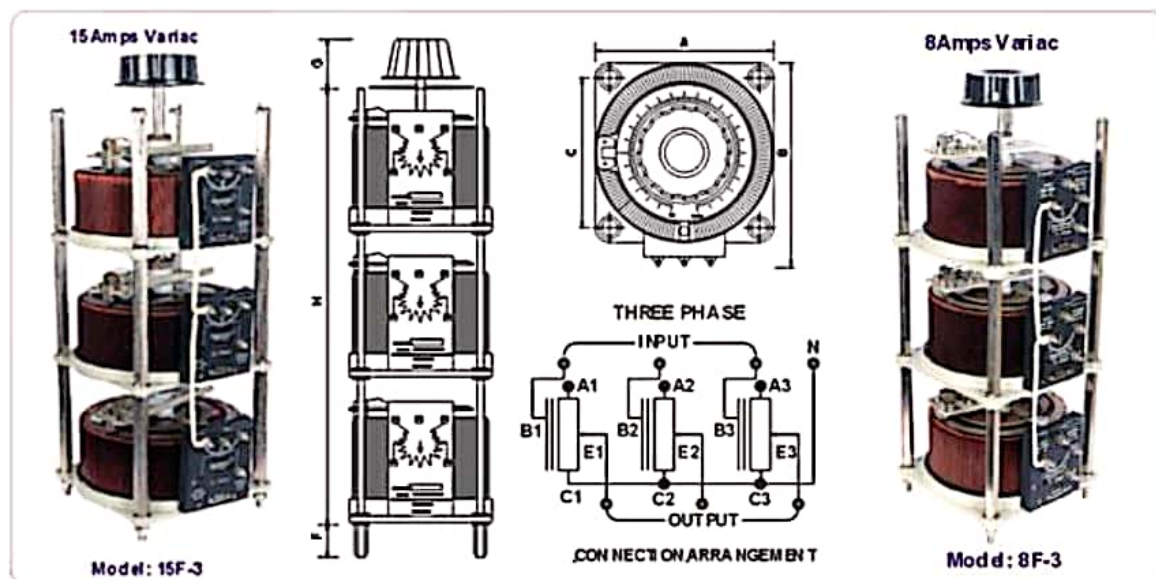

DIAGRAM OF 3 PHASE VARIAC:-



CONCLUSION:-

In the above experiment we overhaul the single phase and 3 phase variac and we conclude that the efficiency of variac is down due to dust and loose contacts.

DISCUSSION QUESTION:-

1. What is variac ?
2. What is the working principle of variac ?
3. Difference between 1 phase and 3 phase variac ?
4. Why need overhaul of variac ?