

JHARSUGUDA ENGINEERING SCHOOL JHARSUGUDA



Lecture Note
On
Mobile Computing

Prepared by
SABYASACHI SARANGI

CONTENTS

SL No.	TOPICS	PAGE
1	UNIT-1 INTRODUCTION TO CLOUD COMPUTING	
2	UNIT-2 CLOUD COMPUTING ARCHITECTURE	
3	UNIT-3 SCALABILITY AND FAULT TOLERANCE	
4	UNIT-4 CLOUD MANAGEMENT AND VIRTUALISATION TECHNOLOGY	
5	UNIT-5 VIRTUALISATION	
6	UNIT-6 CLOUD SECURITY	
7	UNIT-7 CLOUD COMPUTING SECURITY ARCHITECTURE	
8	UNIT-8 MARKET BASED MANAGEMT OF CLOUDS	
9	UNIT-9 HADOOP	

UNIT-1

Computer Network

Connection of various devices like Desktop PC, Laptop, Printer, Scanner, Server etc. with each other through wire or without wire (Known as warless wireless) for data transmission is known as computer network.

Wired Network

In this type of network devices can be connected using CAT5 or CAT6, Co-axial Cable and Optical Fiber.

Wireless network: -

It is a type of network where data can be transmitted between communicating devices without using physical transmission media.

In wireless network radio wave, micro wave, and infrared can be used as transmission media which is also known as unguided media.

The various example of wires communicating devices are cellphone, laptop, DTH (direct to home), wireless keyboard & mouse, TV remote etc.

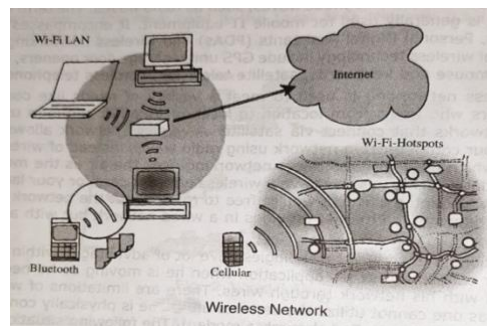

Advantage of wireless network: -

- 1) It can be expanded to any distance.
- 2) It can solve the problem where laydown of cable is not possible.
- 3) It can connect thousands of devices at a time.
- 4) It can connect remote devices.

Disadvantage of wireless network: -

- 1) Lack of network security. Hacker can hack the system or device at any time.
- 2) Implementation of wireless network is very costly.

Mobile computing

It is a computing environment while the user is roaming outside of the building or campus. During roaming or moving, the user can able to access data, information & hardware or software from the server through network. The mobile computing process allows the user to perform any task from anywhere (public place) using a computing device.

For an effective mobile computing environment, it is necessary that the communication system should be spread over both wired and wireless network.

Example of Mobile Computing devices are Cellphone, Laptop, Wi-Fi Dongle, Access Point Etc.

Various dimensions of mobile computing: -

- 1) **Location awareness:** - A mobile device is not always at the same place so to maintain the location of the user various application are used for locating the device.
- 2) **QOS (quality of service):** - In a mobile computing network, connection can be lost at any time. So, it is the responsibility of the service provider to provide better service to the user so that the loss of network connection can be minimized.
- 3) **Limited device storage capacity:** - Most of the wireless device have limited storage capacity. Now the engineers are trying to improve the storage capacity of the mobile device day by day.
- 4) **Limited power supply:** - All the mobile devices are running in the battery power. Due to small size of mobile device the battery size is very small. So, the battery provides a limited power supply to the mobile. If the battery goes down then the device will also shut down or turn off.

Characteristics of mobile computing: -

- 1) **User mobility:** - The mobile computing provides user mobility facility that means a user can moves from one pace to other place while using mobile devices.
- 2) **Network mobility;** - A user can move from one network to other network and user will get the same type of service from the other network.
- 3) **Bearer mobility:** - User of a mobile device can move from one bearer to other bearer and the user gets the same service and facility, for example an user uses WAP (wireless application protocol) technology in a particular area but when the user moves to other area where there is no WAP facility but the user can get the same service from the new bearer in other format.
- 4) **Device mobility:** - **User** can transfer its task from one device to other device and the user will get the same facility.
- 5) **Session mobility:** -User's session can be moved from one device to another device without any interruption.
- 6) **Service mobility:** - User can be able to switch between various services while roaming.

Mobile computing functions: -

1. **User with device:** - It is a fixed device like desktop, pc, laptop, cellphone, palmtop, etc.
2. **Network:** - It can be used by a user in different places at different time when the user is in a roaming mode.
3. **Gateway:** - It converts one specific application or bearer to other application or bearer. For example, from a fixed phone we access the services by pressing different keys on the phone. These keys generate DTMF (dual tone multi-function). These are analog signal which are then converted into digital format by IVR (interactive voice response).
4. **Middle ware network:** - In the middle ware, an application software functioning between operating system and user.
5. **Content:** - It is a server where the original contents are stored. This can be application system of both application and server. This server is connected to database to access various data as per the user requirements.

Application of mobile computing: - GPS SYSTEM, TRAFFIC CONTROL, WATCHING VIDEO WHILE MOVING, ACCESSING EMAIL, GETTING THE POSITION OF TRAIN ETC.

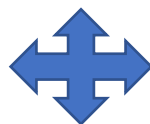

UNIT-2

Introduction to mobile development framework

Client server architecture

It is a type of architecture where all the computers including remote computers known as CLIENT are connected through wire or without wire to a High-End computer called SERVER. Many clients can access the server's information simultaneously, and, at the same time, a client computer can perform other tasks, such as sending e-mail. Because both client and server computers are considered intelligent devices

This type of network architecture can provide an interface in such way, so that a client can send request to the server for various kind of services like Operating System, Database, Files, Software, Hardware, Internet etc.

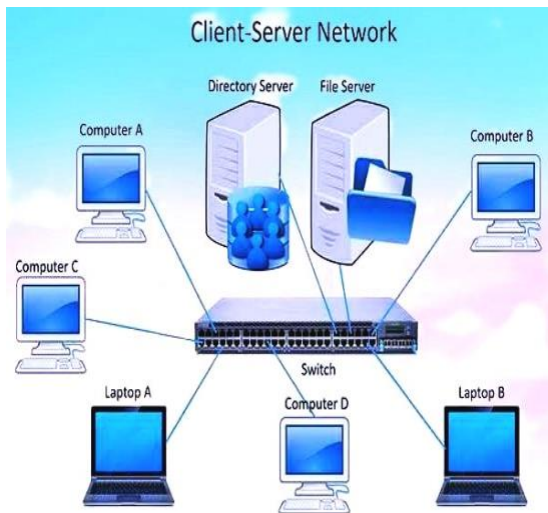

Server: It is a High-End computer that always receives the request from other computers, known as clients, over a network and provides various kind of services, resources, data, to the clients. The various types of Server are...

Application Server, File Server, Print Server, Mail Server, Database Server, Web Server and so on...

Client: It is a type of computer that accesses various services made available by a server as part of the client-server network model. The various types of client computers are...

1. Thick Client
2. Thin Client
3. Hybrid Client

For example, in a banking system a client computer can be running an application program for entering customer information while the server computer is running another program that manages the database in which the information is permanently stored.

Advantages: -

- Centralized server is more stable and reliable.
- Security can be provided by the server.
- Server can be access from different places.
- Data can be stored centrally.

Disadvantage: -

- Due to central server the entire network goes down if the central server has any problem.
- The central server required regular maintenance and updating
- Installation of server is very costly.

Types of Client Server Architecture

There are four main categories of client-server computing:

One-Tier architecture: consists of a simple program running on a single computer without requiring access to the network.

In this category of client-server setting, the user interface, marketing logic and data logic are present in the same system. This kind of service is reasonable but it is hard to manage due to data variance that allots replication of work. One-tier architecture consists of layers.

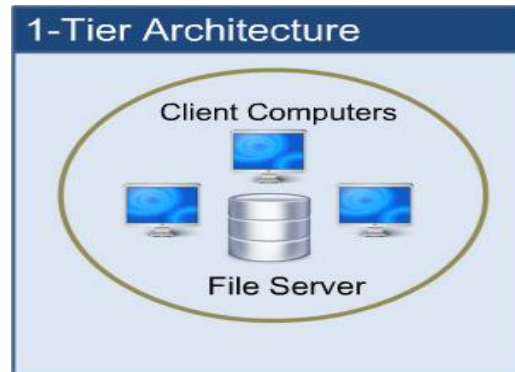

For example, Presentation, Business, Data Access layers within a single software package. The data is usually stored in the local system or a shared drive. Applications which handle all the three tiers such as MP3 player, MS Office come under one-tier application.

Two-Tier architecture: In this type of client-server environment, the user interface is stored at client machine and the database is stored on the server. Database logic and business logic are filed at either client or server but it needs to be maintained.

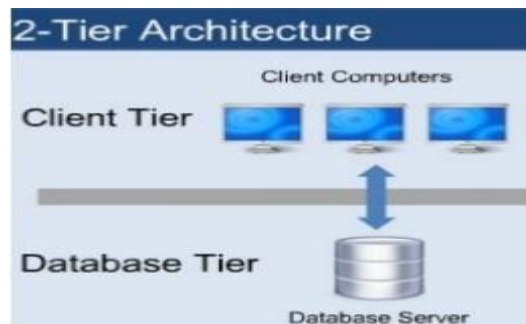

It consists of **Client, Server, and Protocol** that creates a link between client and server. The Graphical User Interface code resides on the client host and the domain logic resides on the server host. The client-server GUI is written in high-level languages such as C++ and Java.

In two-tier architecture, client and server have to come in direct incorporation. If a client is giving an input to the server there shouldn't be any intermediate. This is done for rapid results and to avoid confusion between different clients. For instance, online ticket reservations software uses this two-tier architecture.

Three-Tier architecture: In this type of C/S model, there are three levels of communication process. The 3-Tier architecture divided into 3

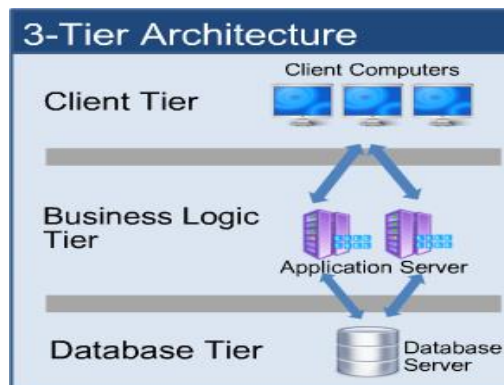

parts Presentation layer (Client Tier), Application layer (Business Tier) and Database layer (Data Tier). This architecture increases productivity through the practice of cost-efficient user interfaces, improved data storage, expanded connectivity and secure services.

The **Three-tier architecture is split into 3 parts**, namely, Presentation layer (Client Tier), Application layer (Business Tier) and Database layer (Data Tier). The Client system manages Presentation layer; the Application server takes care of the Application layer, and the Server system supervises Database layer.

N-Tier architecture: It is more than 3-tier and also known as multi-tier architecture where the Presentation, Processing, and Data functions are divided into logically and physically. The n tier architecture is usually associated with www or web services. The web server provides the web service as per the client request. The good example is online shopping.

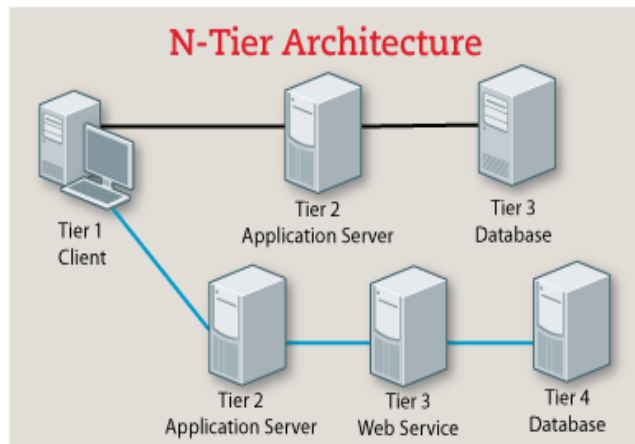

With n-tier architecture, we can adopt new technologies and add more components without having to rewrite the entire application or redesigning our whole software, thus making it easier to maintain.

Basically, it is an industry-proven software architecture model. It is suitable to support enterprise level client-server applications by providing solutions to scalability, security, fault tolerance, reusability, and maintainability. It helps developers to create flexible and reusable applications.

Benefits of N-Tier Architecture

- **Secure:** You can secure each of the three tiers separately using different methods.
- **Easy to manage:** You can manage each tier separately, adding or modifying each tier without affecting the other tiers.
- **Scalable:** If you need to add more resources, you can do it per tier, without affecting the other tiers.
- **Flexible:** Apart from isolated scalability, you can also expand each tier in any manner that your requirements dictate

P 2 P OR (Peer to Peer)

It's a network in which the computers are managed independently of one another and have equal rights for initiating communication with each other, sharing resources, and validating users.

A peer-to-peer network has no special server for authenticating users. Each computer manages its own security, so a separate user account might need to be created for each computer that a user needs to access. Users usually store files on their own computers and are responsible for ensuring that those files are appropriately backed up. In a peer-to-peer network, each computer typically runs both client and server software and can be used to make resources available to other users or to access shared resources on the network.

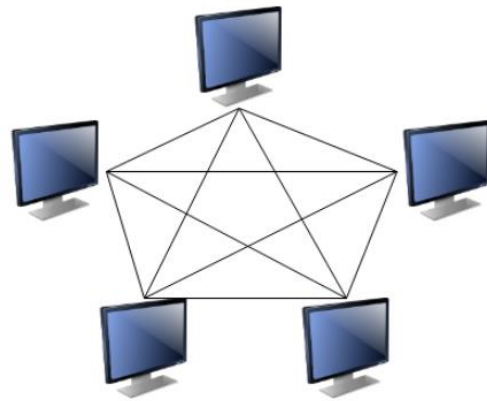

Peer-to-peer networks are simple to set up and are often ideal for small businesses that have fewer than 10 computers and that cannot afford a server-based solution. The disadvantages of peer-to-peer networks are poor security and lack of centralized file storage and backup facilities.

Some uses of P2P architecture:

- File sharing
- Instant messaging
- Voice Communication
- Collaboration
- High Performance Computing

Some examples of P2P architecture:

- Napster - it was shut down in 2001 since they used a centralized tracking server
- Bit Torrent - popular P2P file-sharing protocol, usually associated with piracy
- Skype - it used to use proprietary hybrid P2P protocol, now uses client-server model after Microsoft's acquisition

Advantages: -

- It is very easy to install.
- Few hardware is required for installation.
- No central server is required.

Disadvantage: -

- User cannot store data centrally.
- Lack of security is much higher than client server model.

Difference between Client-Server and Peer-to-Peer Network:

S.NO	CLIENT-SERVER NETWORK	PEER-TO-PEER NETWORK
1.	In Client-Server Network, Clients and server are differentiated, Specific server and clients are present.	In Peer-to-Peer Network, Clients and server are not differentiated.
2.	Client-Server Network focuses on information sharing.	While Peer-to-Peer Network focuses on connectivity.
3.	In Client-Server Network, Centralized server is used to store the data.	While in Peer-to-Peer Network, each peer has its own data.
4.	In Client-Server Network, Server respond the services which is request by Client.	While in Peer-to-Peer Network, Each and every node can do both request and respond for the services.
5.	Client-Server Network are costlier than Peer-to-Peer Network.	While Peer-to-Peer Network are less costly than Client-Server Network.
6.	Client-Server Network are more stable than Peer-to-Peer Network.	While Peer-to-Peer Network are less stable if number of peer is increase.
7.	Client-Server Network is used for both small and large networks.	While Peer-to-Peer Network is generally suited for small networks with fewer than 10 computers.

N tier and www: -

- The n tier architecture is usually associated with www. The web service is based on client server architecture and the communication is made through http or some other protocols.
- The web server provides the web service as per the client request. The good example is online shopping.

Consider Amazon.com as an example:

- Amazon needs to be accessible from anywhere, anytime and on any platform (PC; Tablet; Smartphone) so just on the **Presentation Tier** there are, in fact, several tiers with distinct “flavors” (Windows, iOS, Android).
- **The Business Logic Tier** itself comprehends not only servers distributed by several geographies processing data, but also automated input from warehouses and logistics

components (tiers) that process data by themselves (distinct software layers) to convey information to the Amazon Business Logic Tier (so several tiers here also).

- Finally, the **Data Tier** is not only replicated and distributed but split as well into distinct levels of data instances (layers) in separate servers (tiers).

Mobile agent architecture; -

Mobile agents are small intelligent programs that travel around in a computer network. They are given instructions by the user or programmer and then wander out in the network to accomplish their assigned task. They can be told to collect information, report problems, perform computations or modify existing programs on other computers in the network. In order to work, the mobile agents need a special infrastructure in the network that handles the execution and transportation of the agents. Mobile agents are a new technology that has emerged with the increased use of computer networks and the arrival of the Internet and web technologies.

Applications of Mobile Agents

Several applications benefit from the use of mobile agent technology. Some of these include

Electronic Commerce:

Many commercial transactions require access to resources in real time. The ability of a mobile agent to personify their creators' intentions and to act and negotiate on behalf of them makes it well suited for electronic commerce.

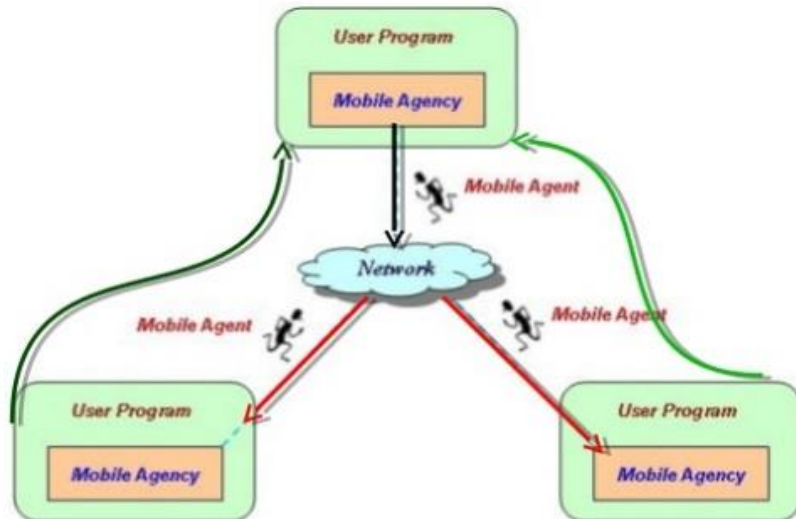

Personal Assistance: An agent can act as a personal assistant to the user and perform tasks for user on a remote host regardless of whether or not user is connected to the network. For instance, to schedule a meeting, a user can dispatch a mobile agent onto the network to interact with agents belonging to other users. The agent can negotiate with other agents the convenient time for all of the users and can schedule a meeting.

Telecommunication networks services: Mobile agents provide an effective and flexible solution to the management of advanced telecommunication services by providing dynamic network reconfiguration and user customization.



UNIT- 3

Wireless transmission

In the physical layer of the OSI model, data is transmitted in the form signal using a transmission media. That transmission media may be a physical cable or it can be an open space called wireless transmission media. In wireless transmission media, we are using radio wave, micro wave and infrared as a signal for data transmission. In standard wireless transmission process, we are using radio wave as transmission media.

Signal

It is the physical representation of data. Data can be either analog or digital. For an example, human voice is always an analog data but the television video and voice are digital signal. Both analog and digital signals are periodic.

The various signal parameters are AMPLITUDE (A), FREQUENCY (F) and PHASE (P).

Analog signal: -A simple analog signal is a sine wave. The sine wave is the most fundamental form of analog signal. The periodic signal completes a pattern within a time frame is called periodic signal. The completion of one full pattern is called cycle. Analog signal requires less bandwidth as compare to digital signal and also it has simple circuit to transmit data.

Digital signal: -It is a type of signal that carries the information in the form of **off/on or 1/0 pulse**. Digital signal consists of pulses. The value of each pulse is constant. It has two amplitude levels that is **0 and 1**. Sometime it is also called true and false. Digital signal requires high bandwidth as compare to analog signal and it also requires a very complicated circuit to transmit data over the network.

Analogue and Digital

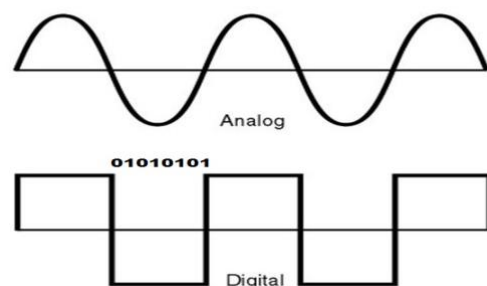

Period and frequency of wireless

- Period is the amount of the time that a signal needs to complete one cycle.
- Frequency is the measurement of the no. of occurrence of repeated signal per second. It can also be defined as no. of periods in one second.

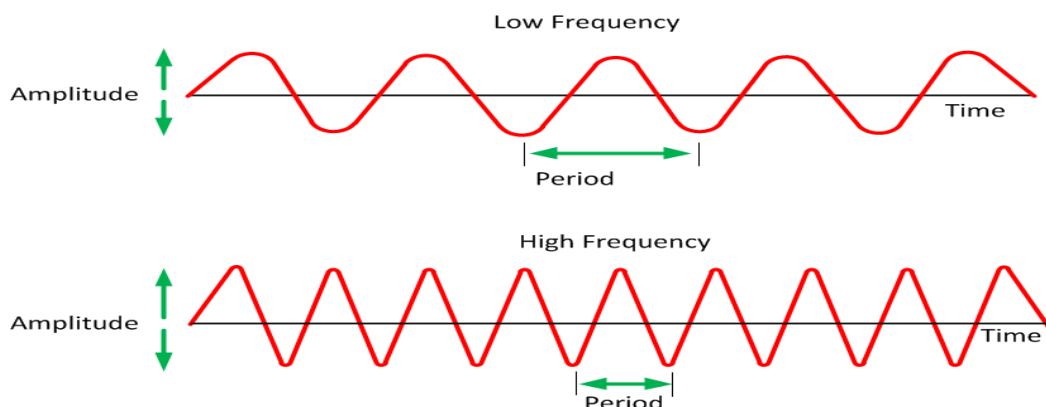

Bandwidth

Network bandwidth is the capacity of a wired or wireless network communications link to transmit the maximum amount of data from one point to another over a computer network or internet connection in a given amount of time that is in one second, It is also known as Data Transfer Rate,

In other words, it is the difference between the highest frequency and the lowest frequency of the transmission media. For example, if a transmission media carries frequencies between 1000 and 6000 than the bandwidth of the transmission media (6000-1000=5000).

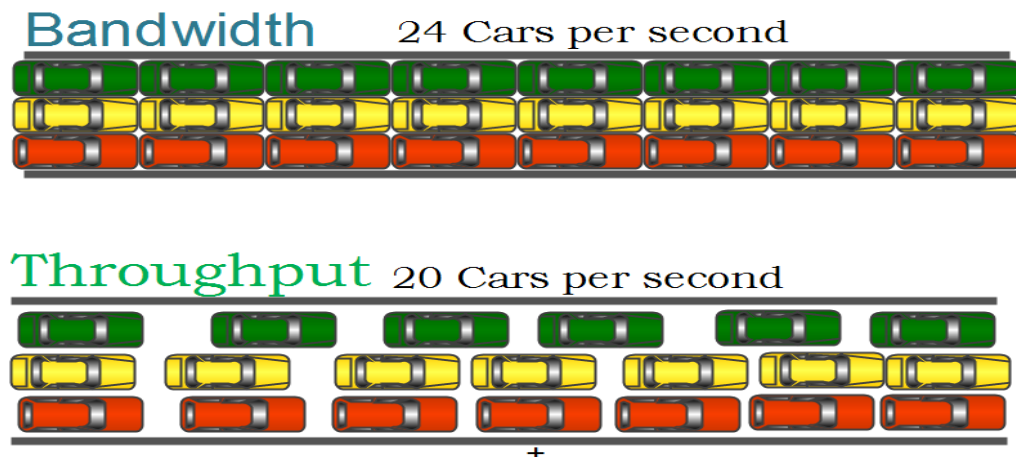

Antenna

It is a type of device which is used for sending and receiving of radio waves. It is also known as transducer. Mainly it is used in broadcasting of television network, wireless network and radio network. It always sends and receives radio signals.



Antennas are designed to transmit and receive signals in all directions equally (omnidirectional antennas), or in a particular direction (directional antennas).

The first antenna was built in 1888 by German physicist Heinrich Hertz in his pioneering experiments to prove the *existence* of waves predicted by the electromagnetic theory of James Clerk Maxwell.

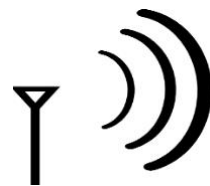

There are mainly two types of antennas we are using.

1. **Omni directional antenna** transmits signal in all directions. But wireless LAN and WAN uses omnidirectional antenna for data transmission. MOBILE PHONE is good example of omnidirectional antenna
2. **Directional antenna** or **Beam antenna** is an antenna which radiates or receives greater power in specific directions allowing increased performance and reduced interference from unwanted sources. Directional antennas provide increased performance over omnidirectional antennas. DTH is good example of directional antenna

Propagation mode of wireless communication

Propagation mode is the process of traveling signals from sender to receiver is known as propagation mode of channel/signal. It can be used in both guided and unguided media. In unguided media the signal travels in the following format. These are

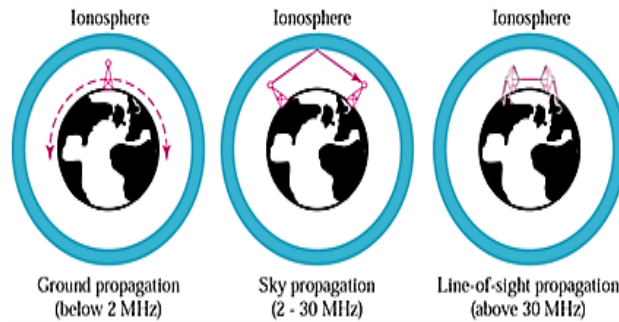

1. Ground propagation mode
2. Sky propagation mode
3. Line of sight propagation mode

- **Ground propagation mode: -**

In this type of propagation mode, the radio wave travels towards lowest portion of the atmosphere. It uses low frequency signals and it transmits the signal in all direction. In this technique if the signals strength is strong, then the signal will cover a large area. Very large range propagation mode is possible using this type of propagation mode.

- **Sky propagation mode: -**

In this propagation process, the signal will move from the sender to the ionosphere, then from ionosphere it will come back to the receiver using refraction technology. At the ionosphere, the signal strongly refracted and ultimately it come back to the ground level. This type of propagation mode has 2-30 MHz of frequency band.

- **Line of sight propagation mode: -**

In this process, the signal is transmitted from sender to receiver directly. In other words, the signal is transmitted from point to point. In this technique no refraction technology is required. Both the sender and the receiver is aligned in a same line or point to point basis. In this propagation mode very high frequency band that is 30 MHz can be transmitted. In this transmission process any kind of obstacle or natural calamities are not allowed.

Multiplexing

The combination of signals, is known as multiplexing. It is a technique that provides a mechanism to share the use of common channel by two or more devices. In this technique more than one signal can be sent using a single transmission channel or media. Mobile cellular system uses various techniques to allow multiple users to access the same radio signals at the same time. Multiplexing can be achieved in various ways. The various multiplexing techniques are: -

1. SDM (SPACE DIVISION MULTIPLEXING)
2. FDM (FREQUENCY DIVISION MULTIPLEXING)
3. TDM (TIME DIVISION MULTIPLEXING)
4. CDM (CODE DIVISION MULTIPLEXING)



Multiplexing and Demultiplexing

Space Division Multiplexing

In this technique the available space is divided along with the user and allowed to transmit data using the same transmission channel at the same time. Channels are assigned on the basis of space with frequency further it assures that there is no interference between users. IN this technique, overlap and recovery of each signal is possible at the receiver site. It uses a guard band that consist of unused frequency of the channel to avoid overlapping and interference.

SDMA (space-division multiple access)

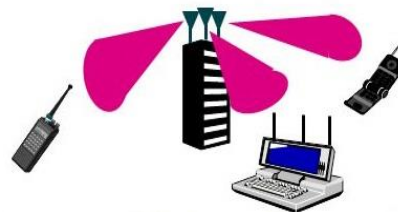

Frequency division Multiplexing

It is a technology in which each signal is allocated a frequency slot within the sane transmission channel. In other words the total available frequency bandwidth in the transmission channel is divided into several frequency channels and each channel is assigned to one information signal and the information signal carry the assigned frequency bandwidth throughout the transmission process. At the receiving end of the transmission channel individual channels are separated by using a circuit called D-multiplexer and handed over to the proper user.

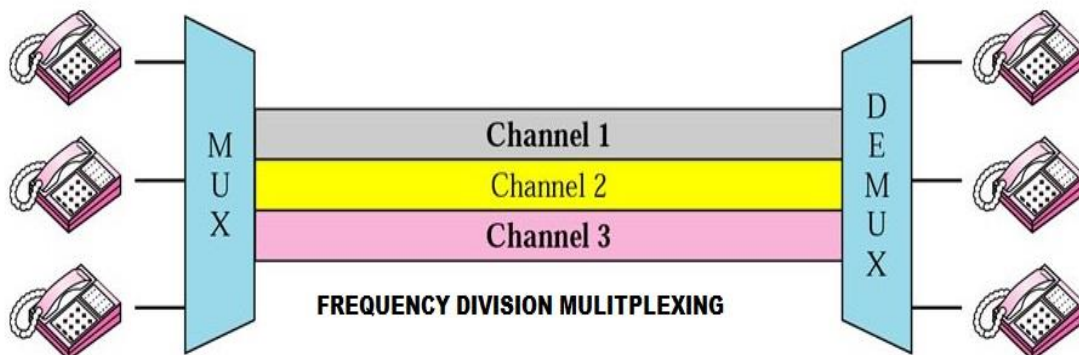

Time Division Multiplexing

It is a type of multiplexing where two or more channels of information are transmitted over the sane transmission channel by allocating different time intervals through transmission channel. At the receiving end, a different type of signal is required to separate the data signal fir each user. The TDM is inefficient when the traffic is less or there is no data transmission.

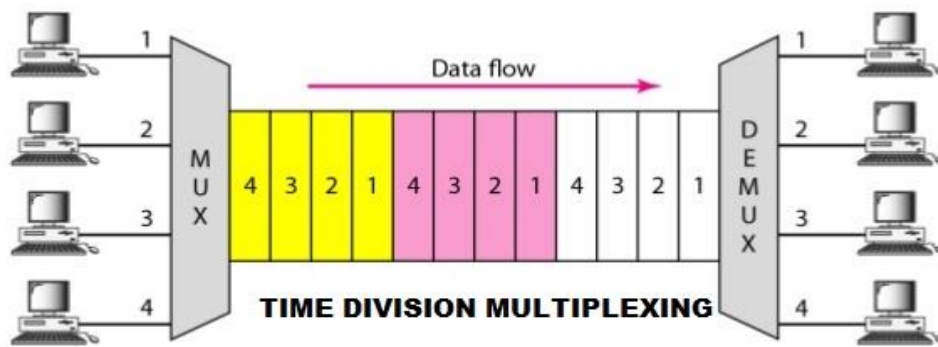

Code Division Multiplexing

It is a technique in which each channel transmits its data bits in the form of pulse. It allows signal from individual user to be transmitted at the same time over the same frequency band. At the receiving end particular code is again converted into signal and handed over to the appropriate user. In this process, all users having different code can be transmitted on fiber optic cable. It is also known as spread spectrum.

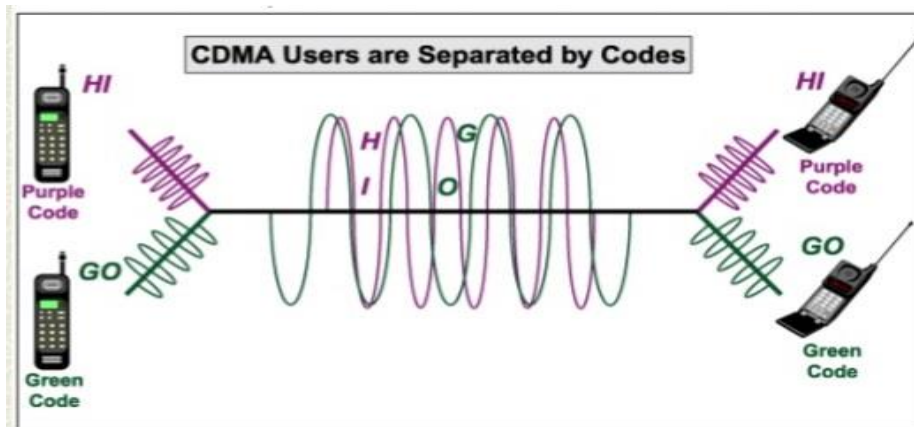

Modulation

Signal consists of two components data or information signal and carrier signal. Before the transmission both the signals are combined together and transmitted in the channel. The process of combining the signal is called modulation and the new generated signal is called modulated signal. The modulation process can change the amplitude and frequency and phase of the carrier signal. A device that performs the modulation process is known as Modulator and the device that performs reverse process of the signal is called Demodulator. A device that can perform both work is called MODEM. There are mainly two types of modulation process i.e., analog modulation, digital modulation process. Now third modulation is added called phase modulation.

Analog modulation

Conversion of analog signal, is called analog modulation. The various analog modulation are as follows: -

- **Amplitude modulation (AM)**

It is a modulation technique used in electronic communication, for transmitting information via a radio carrier wave. In amplitude modulation, the amplitude (signal strength) of the carrier wave is varied in proportion to that of the message signal.

In this modulation the amplitude of the carrier is modulated as per the message signal. The other facts of the carrier signal like frequency and phase remains

constant. This form of modulation is not so efficient way to transmit data because it requires huge power supply as compare to FM technology. AM was the earliest modulation method used for transmitting audio in radio broadcasting.

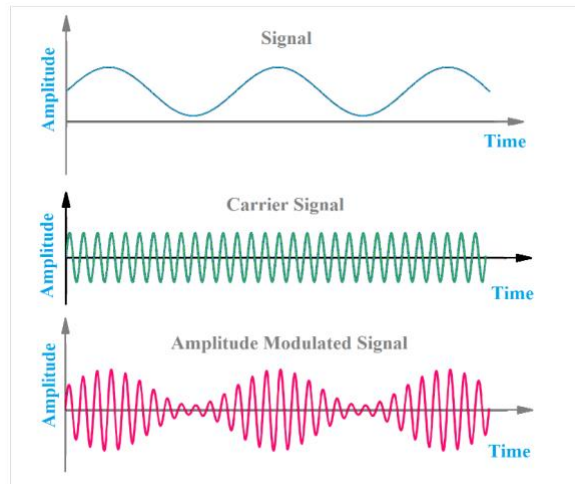

- **Frequency modulation (FM)**

In this modulation, only frequency of the carrier wave can be changed along with the audio signal. In this process, amplitude and phase of the carrier wave remains constant. This technology is developed to overcome the problems of interference and noise which is created in amplitude modulation technology. It is used for radio programs to avoid noise. It can be also used for the broadcasting of audio portion of TV network.

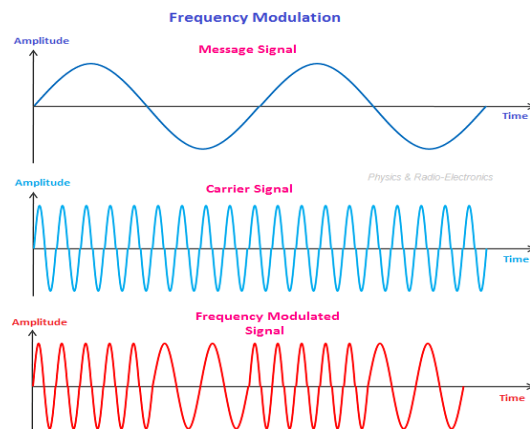

- **Phase modulation (PM)**

In this modulation, the information can be transmitted in the form of phase of a transmission media. It is widely used for transmitting radio wave and it is an integral part of many digital transmission like Wi-Fi GSM and satellite TV network.

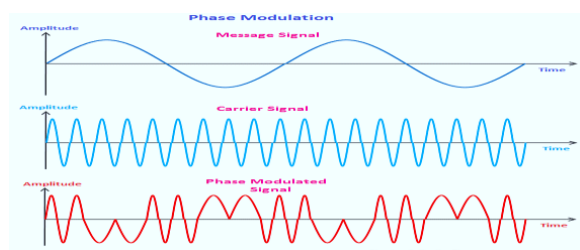

Digital Modulation

In digital modulation an analog carrier signal is modulated by digital bit streams of either equal or varying signal. This is also known as analog to digital conversion. The various types of conversion are: -

- **Frequency shifting key**

It is a frequency modulation scheme in which digital information is transmitted through discrete frequency changes of a carrier signal. The technology is used for communication systems such as telemetry, caller ID, garage door openers, and low frequency radio transmission in the VLF (**Very low frequency 3 to 30 KHz**) and ELF (**Extremely low frequency 3 to 30 Hz** only) bands.

It allows digital information to be transmitted by changing the frequency of carrier signal which is also known as sine wave. There are 2 binary states in a digital signal i.e. 0 and 1. These binary data is converted using FSK technology which can be transmitted through telephone line, fiber optic and wireless transmission media.

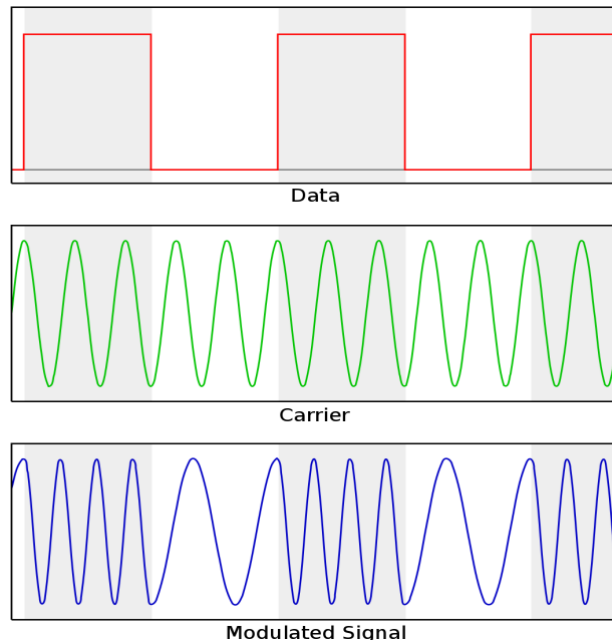

- **Amplitude shifting key**

It is the technology where the amplitude of the carrier wave can be modulated with digital signal and transmitted through the transmission channel.

In this process, if the modulated signal has the value that is 1 then the signal can be transmitted. If the modulated signal has the value i.e., 0 then the signal cannot be transmitted.

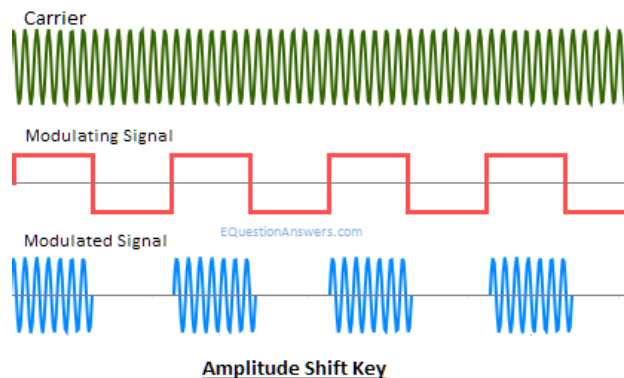

- **Phase shifting key**

It is a digital modulation scheme based on changing of the carrier signal. It transmits data by modifying the phase of a carrier signal. It is used in wireless LAN, Bluetooth technology and RFID (radio frequency identification standard used for biometric processes).

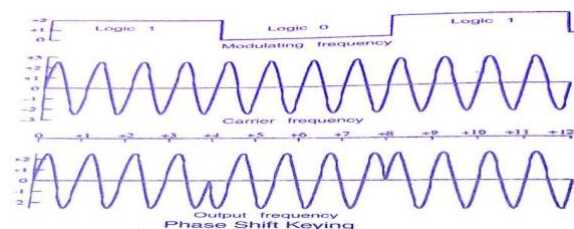

Speed spectrum: it is radio frequency communication system in which the signal bandwidth is spread over a large area by injecting a higher frequency signal. In spread spectrum technology the transmission is much higher than data or information signal. In this technology, first data is modulated for transmission then the carrier is modulated by spreading the bandwidth of the spectrum. The various types of spread spectrum are DSSS (Direct sequence spread spectrum). In this technology, digital information can be transmitted by mixing the information channel with a pseudo code whose bandwidth is much higher than the carrier signal. It uses very low power supply for transmitting the signal. The frequency of the signal is known as ISM (industrial scientific and medical band).

FHSS (frequency hopping spread spectrum)

It is the form of spreading the frequency of carrier signal which can be changed many times within a fix time period. The data signal can move from one place to other place using the frequency range of the carrier signal. In this technology the transmitting device, first verify the channel whether the channel is free or not. If the channel is free then the transmission process starts through the transmission channel.

Cellular system or cell systems

Cellular communications system is a wireless mobile communications system that divides a large geographic area into smaller sections or cells, each with a low-power wireless transmitter, for the purpose of optimizing the use of a limited number of frequencies. A cellular mobile communication system uses a large number of low power wireless transmitters to create cells within the service area of a wireless communication system.

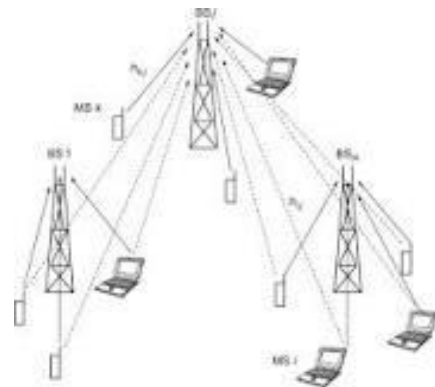

How do cellular systems work?

In the cellular system, **the service area is divided into cells. A transmitter is designed to serve an individual cell.** The system seeks to make efficient use of available channels by using low-power transmitters to allow frequency reuse at much smaller distances.

The power level of a transmitter within the cell must be limited in order to avoid the interference with the other transmitter of neighboring cell.

Cell: -

Cell is the basic geographic unit of a cellular system. A cell can transmit over a small geographic area which is varying depending on the geographic area and landscape. The various type of cells are: -

- **Micro cell:** - it is a type of cell which is used in high density population area where the cell may have a transmitting capacity around 1km.
- **Pico-cell:** - it is a type of cell used for covering very small area like in a building inside a tunnel.
- **Selective cell:** - this type of cell can be used where 360° coverage area is not required.
- **Umbrella cell:** - this type of cell is used in handover process of different neighboring cells.
- **Macro cell:** - this type of cell can be used for remote area and low-density populated area

A cell cluster is a group of cells. No channels are used within the cluster. Number of clusters plays very important role as there are so many no. Of cells in a cluster so each cell capacity should be increased to take care of the data transmission properly and without having any interference.

Frequency reuse

The concept of frequency reuse is based on radio channel used within a particular geographic area. In this technique a cell can be assigned group of channels or no. of channels which is completely different from neighboring channels. In this process, the coverage area of cell is called foot print. This foot print is limited in a particular area so that the transmission channels can be used properly.

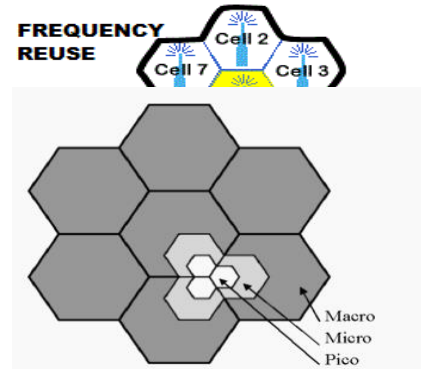

Cell splitting

In this process, a single cell can be splitted into a smaller cell area where more users can be accommodated. This splitting of cells can be used in unburned areas where much more users are there. A large cell can be utilized in remote area, villages as well as less populated areas.

Hand off process/ hand over

- It is happening when the cell phone network automatically transferred to other cell phone network with the same radio frequency without disconnecting the phone call.
- When the mobile unit (cell phone) moves out of the coverage area of a given cell site, the signal becomes weak. At this point of time the mobile device uses hand off process to continue the call
- In this process the signal can be switched from the existing service provider to a new service provider without interrupting the call.

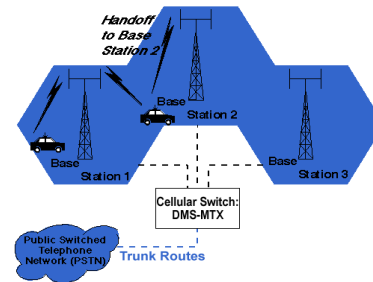

Cellular radio: -

- Each base station provides radio signal to cover a particular geographical area called cell. Base station is connected to one another through central switching system.
- The central switching system tracks the signal and transfer to other cell side accordingly.
- The size of each cell depends on 3 factors: -
 - 1- Environmental condition
 - 2- The frequency band of the signal or the service provider.
 - 3- The capacity of the required cell in any given area.



UNIT-4

Media access control

Introduction

When number of signal sources attempt to access a wireless medium simultaneously the network encounters the problem of receiving signals separately. So to overcome this problem the signals are divided into different cells. These cells are SDMA, TDMA, FDMA and CDMA signals.

The basic access method

The basic access mechanism is carrier sense multiple access (CSMA). It is of two types.

1. **CSMA/ CA (Carrier sense multiple access with collision avoidance)**
2. **CSMA/CD (Carrier sense multiple access with collision detection)**

In CSMA protocol when a station wants to transmit data, first it senses the medium, if the medium is busy than the station will pause its transmission for some time. If the medium is free than the station allows data transmission.

CSMA/CA: In this protocol it uses to “short signaling package” for collision avoidance. These two packages are “Request to send” (RTS) and “Clear to Send” (CTS).

The sender requests the RTS from a receiver before it sends a data package. The receiver grants RTS as soon as it is ready to receive.

CSMA/CD: in this technology the sender first sense the medium to verify whether it is free or not. If the medium is busy the sender will wait until it is free. If the medium is free than the sender starts transmitting data and continuous to listen the medium. If the sender detects a collision file sending, it stops data transmission.

FDMA (Frequency Division Multiple Access)

FDMA assigns individual channels to individual users. Each user is allocated a unique frequency channel. These channels are assigned on demand to subscribers who request service. Guard bands are used to maintain the gap between adjacent signal spectra to minimize cross talk. During the period of the call, no other user can share the same frequency band. In frequency division duplex (FDD) systems, the users are assigned a channel as a pair of frequencies; one frequency is used for the upward channel, while the other frequency is used for the downward channel. This technology is used in all the first generation (1 G) analog mobile networks.

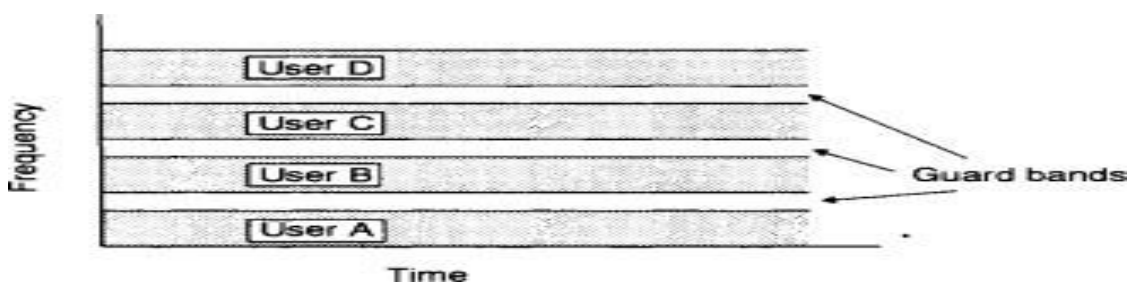

Time Division Multiple Access (TDMA)

Time-division multiple access (TDMA) is a channel access method for shared-medium networks. It allows several users to share the same frequency channel by dividing the signal into different time slots. The users transmit data in a sequence, one after the other, using its own time slot. This allows multiple stations to share the same transmission medium. TDMA is used in the digital 2G cellular systems such as Global System for Mobile Communications (GSM). It was also used in satellite system. It is more expensive technique compared to FDMA because it needs proper synchronization between sender and receiver.

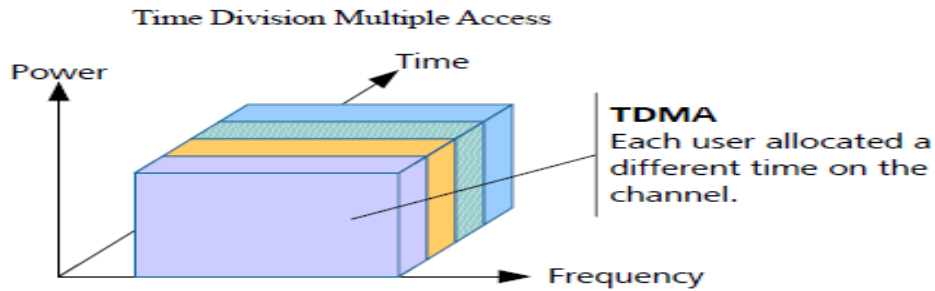

Code Division Multiple Access (CDMA)

It is a broad band system so it is different from FDMA and TDMA. In this technology all subscribers in a cell uses the same frequency band simultaneously. To separate the signals each subscriber is assigned a code called chip. CDMA transmits a weak signal across a wide frequency band. It uses spread spectrum technique where each subscriber uses the entire

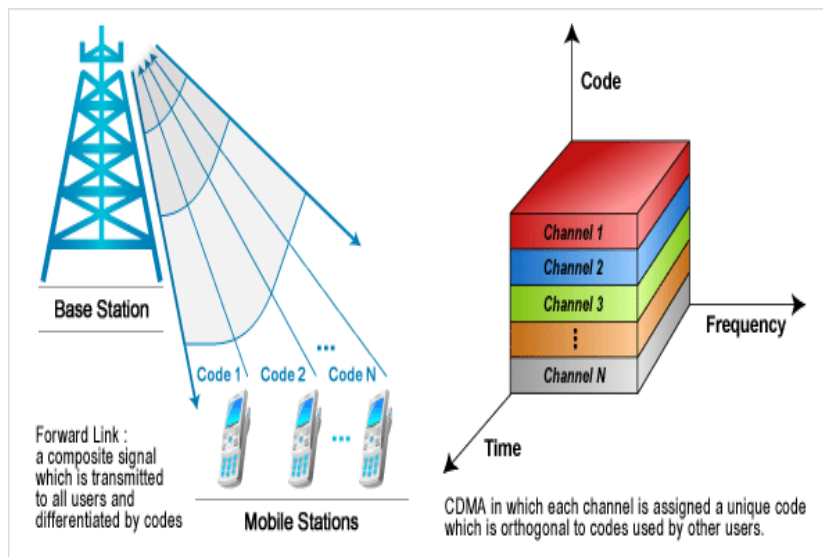

bandwidth. It is used in GPS system, communication and navigation system.

Space Division multiple Access (SDMA):

Space division multiple access or spatial division multiple access is a technique which is MIMO (multiple-input multiple-output) architecture and used mostly in wireless and satellite communication. It has the following features.

- All users can communicate at the same time using the same channel.

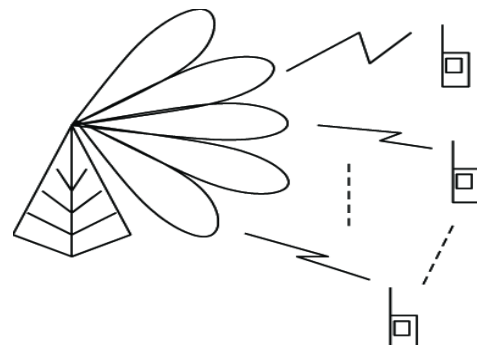

- SDMA is completely free from interference.
- A single satellite can communicate with more satellite's receivers of the same frequency.
- The directional spot-beam antennas are used and hence the base station in SDMA, can track a moving user.
- Controls the radiated energy for each user in space.

Hidden/Exposed Terminal

Hidden Node Problem

In wireless networking, the **hidden node problem** or **hidden terminal problem** occurs when a node is visible from a wireless access point (AP), but not from other nodes communicating with that AP.

Each node is within the communication range of the AP, but the nodes cannot communicate with each other, as they do not have a physical connection to each other.

For Example:

Station **A** can communicate with Station **B**. Station **C** can also communicate with Station **B**. However, Station **A** and **C** cannot communicate with each other since they cannot sense each other on the network, because they are out of range of each other. If **A & C** sends data to **B** at the same time then there will be a collision occur at **B**. So here **A** is hidden terminal for **C** and vice versa.

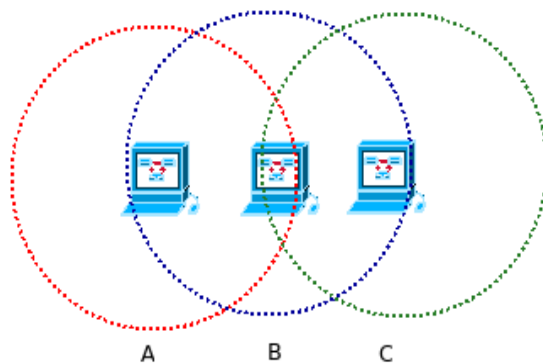

Exposed Terminal

In wireless LANs (wireless local area networks), the exposed terminal problem is a transmission problem that arises when a transmitting station is prevented from sending frames due to interference with another transmitting station. This is prevalent in decentralized systems where there isn't any entity for controlling transmissions. This occurs when a station is visible from a wireless access point (AP), but not from other stations that communicate with the AP.

Example:

Suppose that there are four stations labelled STA, STB, STC, and STD, where STB and STC are transmitters while STA and STD are receivers at some slot of time. The stations are in a configuration such that the two receivers STA and STD are out of radio range of each other, but the two transmitters STB and STC are in radio range of each other.

The above diagram shows that a transmission is going on from STB to STA. STC falsely concludes

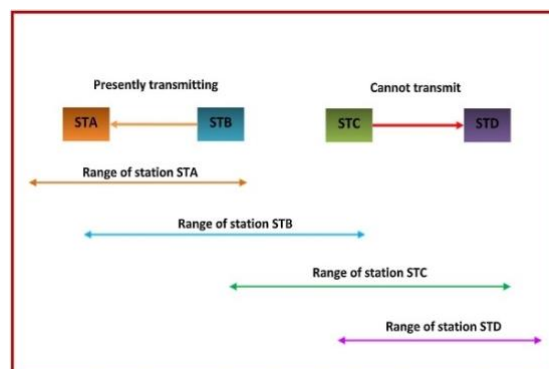

that the above transmission will cause interference and so stops its transmission attempts to STD. However, the interference would not have occurred since the transmission from STC to STD is out of range of STB. This prevention of transmission is called exposed terminal problem.

Solution

The exposed terminal problem is solved by the MAC (medium access control) layer protocol IEEE 802.11 RTS/CTS, with the condition that the stations are synchronized and frame sizes and data speed are the same. RTS stands for Request to Send and CTS stands for Clear to Send.

A transmitting station sends a RTS frame to the receiving station. The receiving station replies by sending a CTS frame. On receipt of CTS frame, the transmitting station begins transmission.

Any station hearing the RTS is close to the transmitting station and remains silent long enough for the CTS. Any station hearing the CTS is close to the receiving station and remains silent during the data transmission.

In the above example, station STC hears RTS from station STB, but does not hear CTS from station STA. So, it is free to transmit to station STD.

Near-far Terminal

It is happening in CDMA based systems in which two transmitters one close to the Base Station and other far from the Base Station transmit at an equal power but the signal received from the closer transmitter has high SNR (Signal to Noise Ratio) (Good) while the Signal received from the far transmitter has low SNR (Bad) at the Base Station. Sometimes the receiver cannot detect the weaker signal received from the far transmitter. In order to receive the signal from the far transmitter, the Base Station will have to increase its transmission power but this will cause more noise. The CDMA Phone which is far from the Base Station will have to transmit at a power higher than the closer transmitters in order to maintain good SNR at the Base station.

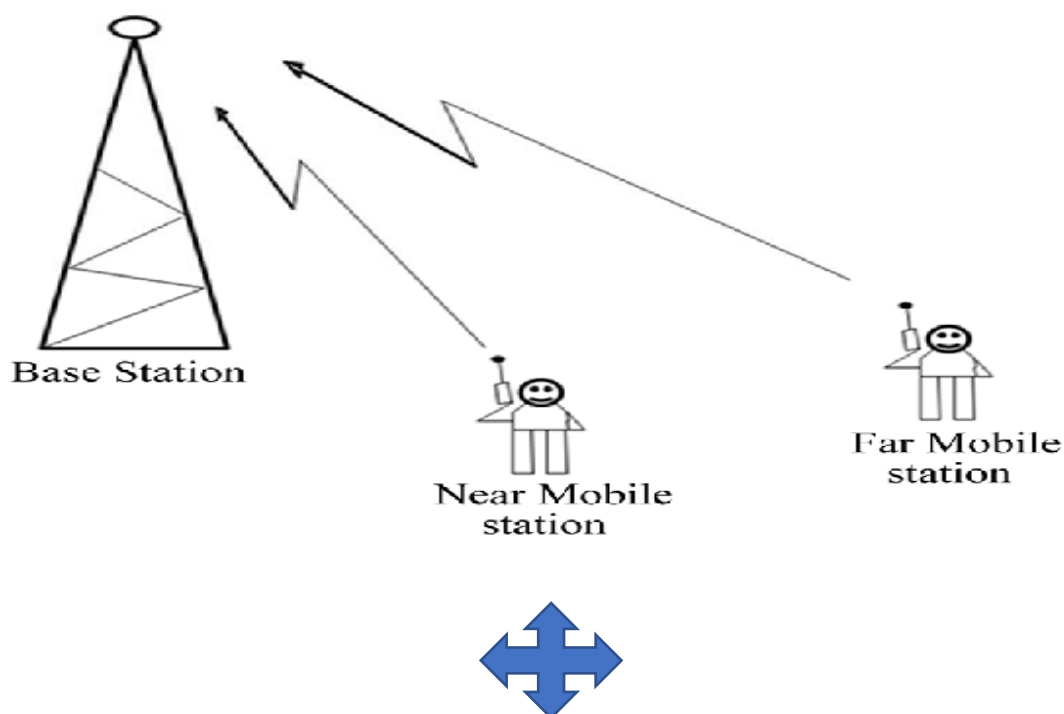

UNIT-5

Wireless LAN and communication

WLAN is known as “**Wireless Local Area Network**”. It provides a flexible data communication without replacing the wired LAN within a building or campus. WLAN uses Radio Frequency, Microwave and Infrared to send and receive data over the air. It allows user mobility in the premises without losing network connectivity.

Infrared

The spectrum between microwaves and visible light is known as Infrared. In infrared, there is a LED that transmits the infrared signal. At the receiving end a photodiode or photoreceptor detects and captures the light pulses, which are then processed to actual data. Some common applications of infrared technology are listed below.

1. Car locking systems
2. Computers Mouse, Keyboards, Floppy disk drives, Printers
3. Navigation systems
4. Telephones
5. TVs, VCRs, CD players, stereos

Infrared technology offers several important advantages as a form of wireless communication. Advantages and disadvantages of IR are

IR Advantages:

- It requires low power so it is suitable for laptops, telephones, PDA etc.
- IR circuit cost is very low for coding/decoding of data.
- Simple circuitry: no special or proprietary hardware is required, can be incorporated into the integrated circuit of a product
- Higher security: directionality of the beam helps ensure that data isn't leaked or spilled to nearby devices as it's transmitted
- Portable
- Few international regulatory constraints: IrDA (Infrared Data Association) functional devices will ideally be usable by international travelers, no matter where they may be
- High noise immunity: not as likely to have interference from signals from other devices

IR Disadvantages:

- Line of sight: transmitters and receivers must be almost directly aligned (i.e. able to see each other) to communicate
- Blocked by common materials: people, walls, plants, etc. can block transmission
- Short range: performance drops off with longer distances
- Light, weather sensitive: direct sunlight, rain, fog, dust, pollution can affect transmission
- Speed: data rate transmission is lower than typical wired transmission

Radio Frequency

RF signal is a high frequency alternating current (AC) signal which is composed of electromagnetic energy. Radio waves are in a form of electromagnetic radiation with identified radio frequencies that ranges from 3Hz to 300 GHz. It is used for transmission of data over wireless communication.

Application

1. Wi-Fi network
2. Bluetooth Network
3. GSM technology

RF Advantages:

1. Not line of sight
2. Not blocked by common materials: can penetrate most solids and pass-through walls
3. Longer range
4. Not light sensitive
5. Not as sensitive to weather/environmental conditions

RF Disadvantages:

1. Interference: communication devices using similar frequencies - wireless phones, scanners, wrist radios and personal locators can interfere with transmission
2. Lack of security: easier to "eavesdrop" on transmissions since signals are spread out in space rather than confined to a wire
3. Higher cost than infrared
4. Federal Communications Commission (FCC) licenses required for some products
5. Lower speed: data rate transmission is lower than wired and infrared transmission

Wireless Network Architecture Logical

Logical architecture defines the network protocol or rules by which two devices can communicate. The most popular logical architecture is **OSI model**. The wireless network deals with only Network Layer, Data-link Layer and Physical Layer of OSI model. This is known as Wireless Network Architecture Logical.

Types of WLAN

There are basically two types of WLAN

1. **Ad-Hoc Network Mode:** It is type of network that connects without using wired network and access point. They can connect each other directly using wireless media for transmission of data with each other. In this type of network all the users can be act as a server also act as a client. This is also known as P2P network. It also known as IBSS - Independent Basic Service Set.
2. **Infrastructure Network Mode:** Infrastructure mode wireless networking joins a wireless network to a wired network.

Setting up an infrastructure mode network it requires at least one wireless access point (AP). The AP and all the local wireless clients must be configured to use the same network name i.e., SSID (**S**ervice **S**et **I**dentifier). The AP is connected to the wired network to allow wireless

clients access. Additional APs can be joined to this network to increase reach of the infrastructure and support more wireless clients.

In infrastructure mode, wireless devices can communicate with each other or can communicate with a wired network. When one AP is connected to wired network and a set of wireless stations is known as a Basic Service Set (BSS). A set of two or more BSSs that form a single sub network is known as Extended Service Set (ESS).

AP: Access points act as a central transmitter and receiver of wireless radio signals.

IEEE 802.11

The 802.11 specification as a standard for wireless LANs was approved by the Institute of Electrical and Electronics Engineers (IEEE) in the year 1997.

The 802.11 standards focus on the bottom two levels the OSI model, the physical layer and Data link layer.

Any type of LAN application as well as network operating system and protocol including TCP/IP and Novell NetWare will run on an 802.11 WLAN.

IEEE 802.11 Architecture

An 802.11 LAN is based on a cellular architecture where the system is subdivided into cells. Each cell (called Basic Service Set) is controlled by a Base Station called Access Point or, in short, AP.

The whole interconnected Wireless LAN, including the different cells, their respective Access Points and the Distribution System, is known as Extended Service Set (ESS).

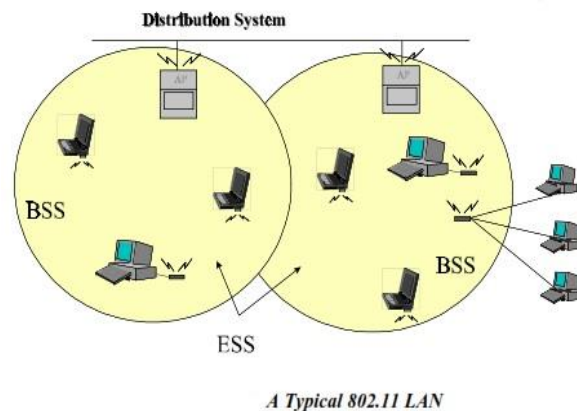

The various component of IEEE802.11 architecture are: -

1: - BSS: - It stands for basic service set. It is a type of service that allows communication with one another. When all of the stations in the BSS are mobile station and there is no connection to a wired network than the BSS is called Independent BSS (IBSS).

IBSS is a temporary network with a small number of mobile devices. When a BSS includes an access point the BSS is called IBSS. In IBSS data can be transmitted through access point only, that means a sender can send the data to access point and the access point sends the data to the receiver. So, it consumes twice the bandwidth of the network.

2: - ESS: - It is known as Extended Service Set. It is a set of infrastructure BSS (IBSS) where all the APs communicate among themselves to forward traffic from one BSS to another BSS and it allows the movement of mobile devices from 1 BSS to another BSS.

3: - DS: - It stands for Distribution System. It is the mechanism by which one AP communicates with another to exchange data packets for mobile station of their own BSS. It also forwards frames to mobile station from 1 BSS to another and exchange data packets with wired networks.

802.11 problems: -

Today 802.11 is rapidly growing protocol for WLAN and Wi-Fi. It faces number of technical challenges. A major challenge is the range or coverage area of the protocol as well as performance of the network and bandwidth of the signal. Other major challenges are how to improve data speed, enhance security and improve quality of service.

The various standards of IEEE802.11 are:

1. IEEE802.11- It is applicable for WLAN and it provides 1 or 2 Mbps transmission with 2.4 GHz bandwidth using either frequency hopping spread spectrum (FHSS) OR direct sequence spread spectrum (DSSS).

- Frequency- 2.4GHz
- Speed -1 to 2 Mbps
- Topology- Ad-hoc / infrastructure
- Transmission range-20 feet (indoor)
- Access method- CSMA/CA

2. 802.11a- It is an extension of 802.11 that applies in WLAN and it provides up to 54 Mbps in the 5 GHz band. It is incompatible with 802.11b and 802.11g wireless standard.

- Frequency / medium- 5 GHz/RF
- Speed- up to 54 Mbps
- Topology – Ad-hoc / infrastructure
- Transmission range-25 to 75(indoor)
- Signals can be affected due to obstacles.
- Access method: - CSMA/CA

3. 802.11b- It provides for a maximum transmission speed of 11 Mbps. However, devices are designed to be backward compatible with previous standards that provides for the speed of 1 2 and 5 Mbps. It uses 2.4 GHz RF and is compatible with 802.11g.

- Frequency/medium- 2.4GHz/RF
- Speed- up to 11 Mbps
- Topology – Ad-hoc / infrastructure
- Transmission range- up to 150 feet(indoor)
- Access method: - CSMA/CA

4. 802.11 g - It is a popular wireless standard today. It offers wireless transmission over distance of 150 feet and speed up to 54Mbps. It operates 2.4 GHz range and it is compatible with 802.11b.

- Frequency/medium-2.4GHz/RF
- Speed- up to 54 Mbps
- Topology – Ad-hoc / infrastructure
- Transmission range- up to 150 feet(indoor)
- Access method: - CSMA/CA

5. 802.11 n - It is the new standard of wireless network for the data transmission over wireless network. It can send data both in 2.4 GHz and 5 GHz frequency range. It uses MIMO (multiple

input multiple output) technology for data transmission. The speed of the standard assumed 600 Mbps but really it transmits the data in 100 Mbps

- Frequency/medium- 2.4Ghz ,5Ghz/RF
- Speed- up to 600 Mbps
- Topology – Ad-hoc / infrastructure
- Transmission range-175+feet (indoor)
- Access method: - CSMA/CA

MAC Layer:

- It stands for Medium Access Control. It is sub layer of Data link Layer of OSI model. This method defines how can use the network medium when multiple users are trying to access the medium simultaneously.
- It establishes reliable Point-to-point connection between different devices over wireless medium.
- It uses CSMA/CA (Carrier Sense Multiple Access/Collision Avoidance) technology while transmitting data over wireless network.

MAC layer is responsible for following functions.

- 1- Reliable data delivery
- 2- Proper control of shared wireless media
- 3- Protect the data that it delivers.

The 802.11 family uses a MAC layer known as CSMA/CA. In CSMA/CA a wireless node that wants to transmit data performs the following sequence.

- 1- First it listens or sense the desired carrier or channel.
- 2- If the channel is free then it senses a packet.
- 3- If the channel is busy then the transmitting node waits until the transmission channel is free.
- 4- When the channel is free it transmits the data packets over the transmission channel.
- 5- After receiving a packet then the receiver sends acknowledgement packet to the sender that the packet is received with error free. If the receiver receives any error or bad packet then it will not send any acknowledgment to the sender.

Security: -

In a wireless transmission security thread is a major issue now a days. The security services offered by 802.11 are: -

1. **Authentication:** - The IEEE802.11 standard defines two types of authentications. One is open system authentication and the other is stored key authentication. The stored key authentication is based on cryptography.

The open system authentication techniques accept any mobile station without verifying the identity of the station. The authentication process is always one way that means only mobile station is authenticated.

2. **Confidentiality:** - The 802.11 standard supports privacy with cryptographic techniques for the wireless network. It is one of the goal or targets of WEP (wired equivalent privacy). It was developed to provide privacy achieved by wired network. The main aim was to prevent information /data loss. It only allows authorized users for data transmission over wireless network
3. **Integrity:** - The IEEE802.11 specification provides data integrity for message transmission between wireless clients and access point. The security service is designed to reject any message that has been changed in the middle of transmission process. This technique uses a single and encrypted cyclic redundancy check (CRC). It ensures that the message is not modified in transmissions between the wireless client and the access point.
4. **Synchronization:** - It is the process of the station in a basic service set (BSS) so that reliable communication can be possible between mobile devices. Mobile nodes need to maintain synchronization. The MAC layer provides the synchronization mechanism to physical layer which makes use of frequency hopping or other time-based mechanisms for data transmission. In wireless network the access point transmits periodic frames called Beacon. Beacon contains the access point's clock at the movement of transmission. This is the time when physical transmission happens. The receiving station check the value of the clock when the signal is received and correct to keep synchronized with the clock of access point. There are two types of synchronization: -
 - **Timer synchronization in IBSS (independent BSS):** - In IBSS the timer synchronization mechanism is completely distributed among the mobile station of BSS.
 - **Timer synchronization in IBSS (infrastructure BSS):** - In infrastructure BSS the AP is responsible for transmitting a beacon frame periodically.

BEACON: It contains all the information about the network. Beacon frames are transmitted periodically to announce the presence of a wireless LAN. Beacon frames are transmitted by the Access Point (AP) in an infrastructure Basic service set (BSS). In IBSS network beacon generation is distributed among the stations.

Power Management

In WLAN the nodes or mobile devices are using battery power for transmitting data or connecting to an AP. These battery powers are very limited. So, this battery power must be saved. In power saving mode devices will go into sleep mode without losing information. The AP maintains all the records of connecting devices and it also buffers the packets of the users during sleep mode. When the user wakeup, the AP will provide the same data to the user. These are of following types:

- **Independent BSS:** It is fully distributed process managed by the individual user.
- **Infrastructure BSS:** In this technique the power management process is centralized in the AP. The AP takes the data buffering burden hand handover when the user weak up.

Roaming

It is the process of moving a wireless device from one network zone to other network zone without disconnecting the network connection.

In WLAN all Aps must contain a SSID (SERVICE SET IDENTIFIER) name which is the unique name in the entire WLAN. All clients connected to Aps with their SSID name when the client move from one network zone to other network zone. The SSID name change automatically without taking the user's permission. To avoid the roaming facility all the Aps must be in a same network that means all the Aps have same services of IP address.

In client side, all the clients must have given permission to access all the Aps in the network it means all the client machines are configured with passwords to access a particular AP. When the client moves from one area to other area it gets the AP signal and continues to transmit data. There is no need to configure the client again.

WLAN standards

Several standards for WLAN hardware exist:

<u>WLAN standard</u>	<u>Pros</u>	<u>Cons</u>
802.11a	<ul style="list-style-type: none">• Faster data transfer rates (up to 54Mbps)• Supports more simultaneous connections• Less risk of interference	<ul style="list-style-type: none">• Short range (60-100 feet)• Less able to penetrate physical barriers
802.11b	<ul style="list-style-type: none">• Better at penetrating physical barriers• Longest range (70-150 feet)• Hardware is usually less expensive	<ul style="list-style-type: none">• Slower data transfer rates (up to 11Mbps)• Doesn't support as many simultaneous connections• More risk of interference
802.11g	<ul style="list-style-type: none">• Faster data transfer rates (up to 54Mbps)• Better range than 802.11b (65-120 feet)	<ul style="list-style-type: none">• More risk of interference
802.11n	The 802.11n standard is recently certified by the Institute of Electrical and Electronics Engineers (Ieee), as compared to the previous three standards. Though specifications may change, it is expected to allow data transfer rates up to 600Mbps, and may offer larger ranges.	

Bluetooth Overview

It is a set of standards for cable free connectivity between wireless devices like mobile phone, laptop, handheld devices etc. The standard is developed by IBM, Intel, Ericsson, Nokia, and Toshiba. It uses rang radio links in 2.4 GHz ISM band (Instrumentation scientific and medical band) which free band.

The Bluetooth technology is inbuilt to the devices and replaces the cable network between laptop to laptop or mobile to laptop. It also replaces the traditional serial cable of mouse and keyboard. Now both the mouse and keyboard can be connected to a computer with the help of Bluetooth.

Other than the cable replacement it also creates Ad-hoc network between Bluetooth enabled devices and transmits data within a short distance of maximum 20 meters.

Bluetooth does not require a point-to-point connection. It is a point to multi point connection.

No line of signal is required in the technology for data transmission. It consumes very low power for data transmission. So, it is much popular in a small and Ad-hoc network

Bluetooth Communication Type

Bluetooth device can connect one or more devices in several different ways. The Bluetooth connections are:

Pico net (Point-to-multipoint connection):

- In Bluetooth connection one device will act as master and the other will act as slave. This type of Ad-hoc network is called Piconet.
- In Piconet connection the master may connect one or more slaves. In this case the connection is called point to multipoint connection. The bandwidth of the channel shared among the connected slaves.

Scatter net

- Multiple Piconets with overlapping coverage areas can be connected to form a scatternet.
- Each piconet can only have a single master; however, slaves can participate in different Piconets on a time-division multiplex basis.
- A master in one piconet can be a slave in another.
- Each piconet is identified by a different hopping frequency sequence. All users participating on the same piconet are synchronized to this hopping sequence.

Link Type in Bluetooth

It uses two types of links for data transmission.

- **Synchronous Connection-Oriented (SCO):** It is a Point-to-Point link between a master and single slave in the Piconet. The master maintains the SCO link. The link is reserved for the slave. So, this link is considered as Circuit-Switched Network.
- **Asynchronous Connection less (ACL):** It is the point-to multi point link between the master and all the slaves in piconet. This link carries asynchronous data. It provides a packet switched link between master and all active slaves.

Packet Format

The data in a piconet transmitted in a packet format. The general packet format consists of Access Code, Header, and Payload.

The Access Code and Header are fixed size of 72 bits and 54 bits respectively. The Payload can range from 0 to 2745 bits.

- Temporary Network
- Up to 8 Active Devices
- Master Coordinates the Piconet and Slaves follow the Master
- Each Bluetooth Device may Operate as Either Master or Slave

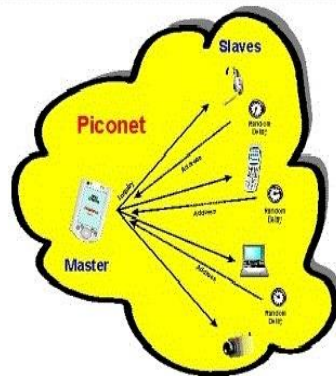

IMAGE OF PICONET

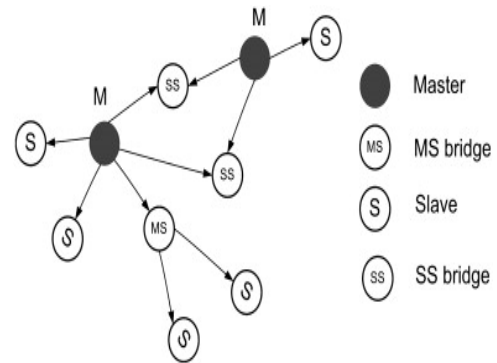

IMAGE OF SCATTERNET

BLUETOOTH PACKET FORMAT

Bits	72	54	0-2744
	Access code	Header	Data

Bits	3	4	1	1	1	8	
	Addr	Type	F	A	S	Checksum	The 18-bit header is repeated three times for a total of 54 bits

- Access code: contain synchronisation bits and the identifier of the primary to distinguish the frame of one piconet from that of another (in case there are several masters within the radio range).
- Address defines up to 7 secondary nodes.
- Type defines link type (e.g., SCO, ACL)
- F: Flow control bit
- A: Acknowledgement bit
- S: Sequence number

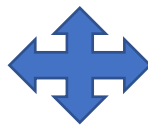

UNIT- 6

INTRODUCTION

The idea of “Anywhere, Anytime, Anything and Anyone (4As) network is known as UBIQUITOUS network. The meaning of UBIQUITOUS is “Being Everywhere at any time”. The main objectives of UBIQUITOUS networking are

1. Free from networking constraints like capacity, location and different link ups
2. Free from the constraints of terminal limitations
3. Free from constraints of limited service
4. Free from constraints of network risk.

SCENARIO OF MOBILE COMMUNICATION

The mobile industry has tremendous growth in the past few years in terms of subscribers. Ultimately the usage of signals also increased. So, the average revenue per user (APRU) is shrinking. So, it is a very big challenge for all the mobile companies to maintain the business profitable. The industry is addressing this challenge in two ways. These are:

- By adding new services or new subscribers to increase the profit.
- By reducing the operating expenses.

There are two primary mobile systems in the industry. These are:

1. Global system for mobile communication (GSM)
2. Code division multiple access (CDM)

Mobile Communication Generation:

The various signal generations are as follows.

1G Network: 1G is the first-generation signal of wireless technology which was first introduced in 1980s and completed in early 1990s. Its Speed was up to 2.4kbps, allowed the voice calls in 1 country. 1G wireless networks used analog radio signals. 1G network were conceived and designed purely for voice calls with almost no consideration of data services

2G Network: The second generation (2G) technology was launched in the year 1991 in Finland. It is based on the technology known as global system for mobile communication (GSM).

This technology enabled various networks to provide services like text messages, and picture messages. The main function of 2G technology is the transmission of information via voice signals. In this technology all text messages are digitally encrypted. So only the intended receiver will receive the message. 2G signal consumes less battery power, so it helps in saving the battery of mobiles. The downloading and uploading speeds available in 2G technologies are up to 236 Kbps.

2G technologies uses TDMA (Time Division Multiple Access) which divides signal into different time slots or CDMA (Code Division Multiple Access) which allocates a special code to each user so as to communicate over a multiplex physical channel.

3G Network

3G is a wireless signal used for mobile phones and telecommunication equipment which are compatible with the International Mobile Telecommunications-2000 (IMT-2000) standards developed by International Telecommunication Union (ITU). It is designed for multimedia communication. It provides services like higher data transfer rates. One of its key visions of 3G is to provide continuous global roaming, enabling users to move across borders while using the same number and handset. The data transfer rate for 3G networks is between 128 and 144 kbps (kilobits per second) for devices that are moving fast and 384 kbps for slow ones (like for pedestrians). While in 3G technology the downloading and uploading speeds are up to 21 Mbps and 5.7 Mbps respectively.

3G has the following features

- Several times higher data speed;
- Enhanced audio and video streaming;
- Video-conferencing support;
- Web and WAP browsing at higher speeds;
- IPTV (TV through the Internet) support.

Universal Mobile Telecommunication System (UMTS)

It is a 3G mobile communication system that provides a range of broadband services to the wireless and mobile communication. It provides low-cost mobile communication at the data rate of up to 2Mbps. It is designed to deliver pictures, graphics, video communications and other multimedia information as well as voice and data to the mobile subscribers. The objectives of UMTS are

1. High transmission rates using circuit-switched and packet-switched technology
2. High spectrum efficiency and overall cost improvement
3. Common radio interfaces for multiple environment
4. Providing services in various environments like Indoor, Outdoor, Suburban, Urban, and Rural, Vehicular etc.

UMTS services

1. **Internet access:** messaging, video and music download, voice and video over IP, M-commerce
2. **Customized information:** information about (photo, video and music), travel assistance, distance education, voice portal service
3. **Multimedia messaging:** Image, video and music
4. **Location based service:** yellow pages, mobile commerce, navigation service, trading etc.

Features

- UMTS is a component of IMT-2000 standard of the International Telecommunications Union (ITU), developed by 3GPP.
- It uses wideband code division multiple access (W-CDMA) air interface.
- It provides transmission of text, digitized voice, video and multimedia.

- It provides high bandwidth to mobile operators.
- It gives a high data rate of 2Mbps. For High-Speed Downlink Packet Access (HSDPA) handsets, the data-rate is as high as 7.2 Mbps in the downlink connection.
- It is also known as Freedom of Mobile Multimedia Access (FOMA).
- It encompasses specifications for the entire mobile network system –
 - Radio access network specified by UTRAN (UMTS Terrestrial Radio Access Network)
 - Core network specified by MAP (Mobile Application Part)
 - Authentication of the users by SIM (Subscriber Identity Module) cards

UMTS architecture

The UMTS network architecture can be divided into three main elements:

1. **UE** or the mobile terminal.

2. **UMTS Terrestrial Radio Access Network (UTRAN):**

UTRAN provides and manages the air interface for the overall UMTS network which consists of two main components:

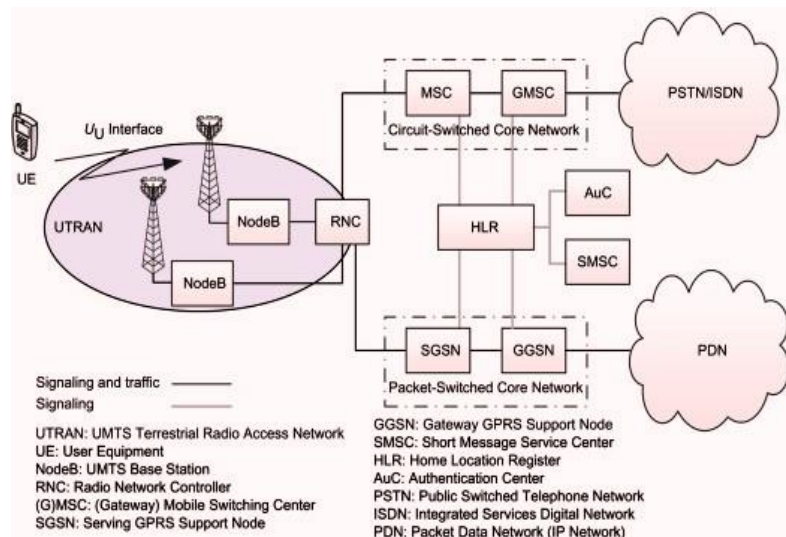

- **Radio Network Controller (RNC):** This element of the radio network subsystem controls the Node B which are connected to it. The RNC undertakes the radio resource management and some of the mobility management functions. It is also the point at which the data encryption/decryption is performed to protect the user data privacy.
 - **Node B:** Node B is the term used in UMTS to denote the base station transceiver. It contains the transmitter and receiver to communicate with the UEs within the cell. In order to facilitate effective HO between Node s under the control of different RNCs, the RNC communicates not only with the CN but also with neighboring RNCs.
3. **Core network:** The CN provides central processing and management for the system as well as interface to external networks, including [circuit-switched] public phone network and other cellular networks. The UMTS CN may be divided into two different areas:

- **Circuit-switched elements:** These elements are primarily based on the GSM network entities and carry data in a circuit-switched manner; that is, a dedicated channel for the duration of the call.
- **Packet-switched elements:** These network entities are designed to carry packet data. This enables much higher network usage as the capacity can be shared and data is carried as packets which are routed according to their destination.

Some network elements in UMTS CN, particularly those that are associated with registration, are shared by both circuit-switched and packet-switched domains and operate in the same way as they did with GSM.

- **MSC:** This entity is essentially the same as that in the GSM network and manages the circuit-switched call flows.
- **Gateway MSC (GMSC):** This is the interface to the external networks.

The packet-switched elements of the UMTS CN architecture include the following network entities:

Serving GPRS Support Node (SGSN): This entity was first developed when GPRS was introduced, and its use has been carried over to the UMTS network architecture. The SGSN provides a number of functions within the UMTS network architecture including the following:

- **Mobility management:** when a UE attaches to the packet-switched domain of the UMTS CN, SGSN generates mobility management information based on the mobile's current location.
- **Session management:** SGSN manages the data sessions providing the required QoS and also managing what are referred to as the Packet Data Protocol (PDP) contexts; that is, data bearers.
- **Interaction with other network elements:** SGSN is able to manage its elements within the network only by communicating with other areas of the network; for example, MSC and other circuit-switched areas.
- **Billing:** SGSN is also responsible billing. It achieves this by monitoring the flow of user data across the GPRS network. Call detail records are generated by SGSN before being transferred to the charging entities.
- **Gateway GPRS Support Node (GGSN):** GGSN is the central element within the UMTS packet-switched network. It handles interworking between the UMTS packet-switched network and external packet-switched networks and can be considered as a sophisticated router. In terms of operation, when GGSN receives data addressed to a specific user, it checks if the user is active and then forwards the data to the SGSN serving that particular UE.

UMTS CHANNELS

The data carried by the UMTS transmission is organized into frames, slots and channels. In this way all the data load as well as the control of data can be transmitted in an efficient manner.

The channels are categorized into three levels. These are:

1. Logical
2. Transport
3. Physical

The logical channel defines the way in which the data will be transmitted. The transport channel along with the logical channel again defines the way in which the data is transmitted. The physical channel carries the data load and controls the physical characteristics of the signal.

UMTS SPECIFICATION AND MANAGEMENT

To maintain UMTS or WCDMA it is necessary to prepare and maintain a large number of documents and specifications. So, these documentation and specifications are now managed by a group known as 3GPP (**3rd Generation Partnership Project**).

The 3GPP is responsible to produce globally applicable technical specifications and technical reports for 3rd generation mobile telecommunication system.

Parameters	1G	2G	3G
Name	1st Generation Mobile Network	2nd Generation Mobile Network	3rd Generation Mobile Network
Introduced in year	1980s	1993	2001
Location of first commercialization	USA	Finland	Japan
Technology	AMPS (Advanced Mobile Phone System), NMT, TACS	IS-95, GSM	IMT2000, WCDMA
Multiple Address/Access system	FDMA	TDMA, CDMA	CDMA
Switching type	Circuit switching	Circuit switching for Voice and Packet switching for Data	Packet switching except for Air Interface
Speed (data rates)	2.4 Kbps to 14.4 kbps	14.4 Kbps	3.1 Mbps
Special Characteristic	First wireless communication	Digital version of 1G technology	Digital broadband, speed increments

Features	Voice only	Multiple users on single channel	Multimedia features, Video Call
Supports	Voice only	Voice and Data	Voice and Data
Internet service	No Internet	Narrowband	Broadband
Bandwidth	Analog	25 MHz	25 MHz
Operating frequencies	800 MHz	GSM: 900MHZ, 1800MHz CDMA: 800MHz	2100 MHz
Band (Frequency) type	Narrow band	Narrow band	Wide band
Carrier frequency	30 KHZ	200 KHz	5 MHz
Advantage	Simpler (less complex) network elements	Multimedia features (SMS, MMS), Internet access and SIM introduced	High security, international roaming
Disadvantages	Limited capacity, not secure, poor battery life, large phone size, background interference	Low network range, slow data rates	High power consumption, Low network coverage, High cost of spectrum license
Applications	Voice Calls	Voice calls, short messages, browsing (partial)	Video conferencing, mobile TV, GPS

4G Signal

4G is a collection of fourth generation cellular data technologies. It succeeds 3G and is also called "IMT-Advanced," or "International Mobile Telecommunications Advanced." 4G was made available as early as 2005 in South Korea under the name WiMAX and was rolled out in several countries.

All 4G standards must conform to a set of specifications created by the International Telecommunications Union. For example, all 4G technologies are required to provide peak data transfer rates of at least 100 Mbps. While actual download and upload speeds may vary based on signal strength and wireless interference, 4G data transfer rates can actually surpass those of cable modem and DSL connections.

Like 3G, there is no single 4G standard. Instead, different cellular providers use different technologies that conform to the 4G requirements. For example, WiMAX is a popular 4G technology used in Europe also in America, while LTE (Long Term Evolution) is more popular in Asian countries.

The benefits of 4G

The benefits of 4G fall firmly into three categories. These are:

- improved download/upload speeds
- reduced latency
- crystal clear voice calls

Standard 4G (or 4G LTE) is around five to seven times faster than 3G, offering theoretical speeds of up to around 150Mbps.

LTE

LTE stands for Long Term Evolution and is a 4G (read: 4th generation) wireless broadband standard. It is the fastest wireless network for smartphones and mobile devices. **LTE** offers higher bandwidth, meaning greater connection speeds, and better underlying technology for voice calls (VoIP) and multimedia streaming.

5G Signal

5G is the 5th generation mobile network. It is a new global wireless standard after 1G, 2G, 3G, and 4G networks. 5G enables a new kind of network that is designed to connect virtually everyone and everything together including machines, objects, and devices.

5G wireless technology is meant to deliver higher multi-Gbps peak data speeds, ultra-low latency, more reliability, massive network capacity, increased availability, and a more uniform user experience to more users. Higher performance and improved efficiency empower new user experiences and connects new industries.

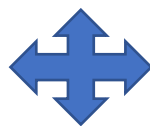

UNIT-7

Mobile IP

Mobile IP is an Internet Engineering Task Force (IETF) standard communications protocol which is designed to allow mobile devices to move from one network to another while maintaining their permanent IP address. Mobile IP is a mechanism for forwarding Internet traffic to mobile devices (known as mobile nodes) when they are connecting through other than their home network. In IP network, routing is based on fixed IP address, similar to a postal letter is delivered to the fixed address on the envelope. A device in a network is reachable through normal IP routing by the IP address it is assigned on the network.

The problem occurs when a device is moving away from its home network and it is no longer able to use its normal IP address. This results in the active sessions of the device being terminated. So, to avoid this problem the Mobile IP concept is developed to keep the same IP address while traveling to a different network.

Mobile IP entities

Mobile network (MN): it is a node that can change the point of connection from one network to another network without changing its IP.

Home Agent (HA): Basically, it is a router that registers the home address of nodes which are away from the home network.

Foreign Agent (FA): it is the device that handles current foreign network for mobile node. These are basically routers.

Care-of –Address (COA): it is an address used by mobile network when it attached to a foreign link. A mobile node assigned a multiple COA.

Correspondent Node (CN): it is the next node that the mobile network can communicate for packet transmission.

Home address (HA): it is an address that is assigned to a mobile node. Basically it is the IP address of the mobile device.

Home link (HL): it is the link that is assigned to a mobile network through which the mobile networks will get the IP address.

Foreign link (FL): it is a link that is not directly connected the mobile network's home link.

Mobility agent

In Mobile IP the mobility agent is a router that facilitates Internet traffic forwarding for a mobile node when its location is changed to somewhere other than its home network. There are two different types of mobility agent:

1. Home agent: It is a router on the mobile node's home network that maintains information about the mobile node's current location, as identified in its care-of address.

2. Foreign agent: It can assign an IP address to a mobile device when the mobile device is away from its home network. This may be a static IP address of the foreign agent or a *co-located care-of address*, which is a temporary IP address assigned to the mobile node.

Working of Mobile IP

1. In IP there are some host addresses and some network address.
2. The network part of the IP address communicates with router and the host part is with the end user.
3. The TCP contains four entities. These are IP address and port number of both sender and receiver.
4. To continue the network without losing the connection we have to ensure that these entities should be remaining constant.
5. The port cannot be changed because it is application based.
6. But the IP will change from network to network. This causes disconnection of live streaming of audio and video.
7. So, to fix this problem the mobile IP concept is developed.
8. The mobile IP allows the mobile device with two IP addresses these two IP addresses are home address and care of address.
9. The home address is the permanent IP address of a mobile device and COA is the temporary IP address of a mobile device. The COA will change from network to network.

Mobile IP Operation

The Mobile IP process has three main phases.

- 1. Agent Discovery or Discovering Care-of-Address:** A Mobile Node discovers its Foreign and Home Agents during agent discovery. During this phase, the Home Agent and Foreign Agent advertise their services on the network by using the Router Discovery Protocol (IRDP). The Mobile Node listens to these advertisements to determine if it is connected to its home network or foreign network. If a Mobile Node determines that it is connected to a foreign network, it acquires a care-of address.
- 2. Registration of Care-of-Address process:** The Mobile Node registers its current location with the Foreign Agent and Home Agent during registration process. The Mobile Node uses this information along with the information that it got from the Foreign Agent to form a Mobile IP registration request.
- 3. Mobile IP Tunneling:** It is a tunnel set up by the Home Agent to the care-of address (current location of the Mobile Node on the foreign network) to route packets to the

Mobile Node while in roaming. The Mobile Node sends packets using its home IP address, effectively maintaining the appearance that it is always on its home network. Even while the Mobile Node is roaming on foreign networks, its movements are transparent to correspondent nodes. Tunneling has two primary functions: encapsulation of the data packet to reach the tunnel endpoint, and DE capsulation when the packet is delivered at that endpoint.

Mobile IP V6

1. It has large address scope which is the global address for each device.
2. It is scalable as it runs over multiple networks like WLAN, Ethernet and 3G.
3. It has auto configuration facility that means it is plug and play.
4. It has fixed header format that means packet header cannot be extended it is fixed while moving in the network.
5. It very much efficient for routing of real time application like live video and audio streaming.

Mobile IP V6 Address Type

The various address type of IPV-6 is as follows:

1. **Unicast:** It is a communication between a single host and a single receiver. It defines a single interface. A packet sent to a unicast address is delivered to the specific computer.
2. **Multi cast:** It is the communication between a single host and multiple receivers. These addresses are used to define a set of interfaces which belongs to different nodes. In this process when packet is sent to a multicast address the protocol delivers the packet to all interfaces.
3. **Any cast:** it is a communication between a single sender and a list of address. These addresses are assigned to more than one interface. Packet can be delivered to just one of the member interfaces. It cannot be identified easily.

Mobile IP V6 Address Scope

1. Link – local: it is used on single link. Packets cannot be forwarded to another link. It can be transmitted between users in the same link.
2. Site-local: it is used for a single site. Packets cannot be forwarded to another site.
3. Global: it is a global unique address. Packets having global address can be forwarded to any part of the globe.



UNIT- 8

WWW architecture for Mobile computing

The WWW architecture provides a very flexible and powerful programming model. Applications and contents are presented in standard data formats and are browsed by applications known as web browser.

Web browser is a networked application that sends request for named data project to a network server and the network server responds with the data encoded using the standard formats.

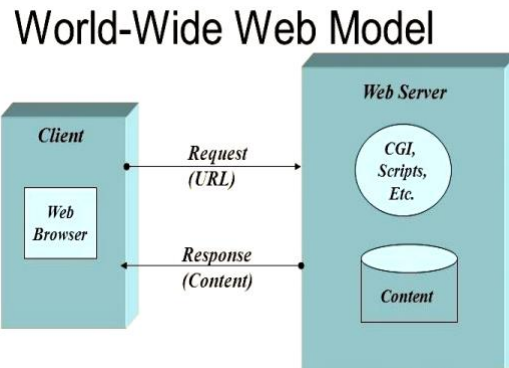

The various mechanisms in WWW standards are:

- **Standard naming model:** All servers and contents on the WWW are named with an internet standard known as Uniform Resource Locator (URL).
- **Content typing:** All contents on the WWW are given a specific type to allow web browsers for processing of the content.
- **Standard content formats:** All web browsers support a set of standard content formats like HTML, scripting languages like JAVA and VB script.
- **Standard protocols:** All the browsers use common protocols like HTTP and TCP/IP protocol suit to connect a web server.

WAP

- **WAP stands for Wireless Application Protocol** is a communication protocol suite specifically developed for mobile devices like mobile phones, personal digital assistants (PDAs) and other hand-held devices.
- WAP is a bridge between the mobile device and the Internet. The WAP was developed by the WAP Forum which is a group of Device manufacturer, Service provider, Content provider, and Application developer.
- The original participants for developing WAP were Motorola, Nokia, Ericsson and Phone.com. Now there are more than 200 members in WAP Forum.

The WAP Architecture

There are three major parts of a WAP-enabled system:

- WAP Device
- WAP Gateway
- HTTP Web Server

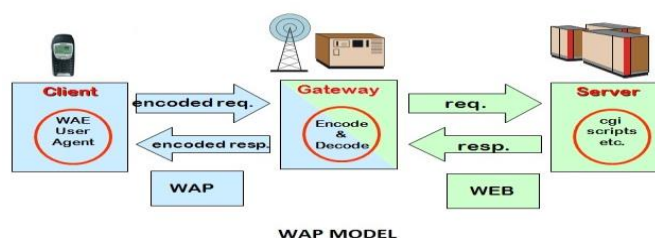

The WAP Device

WAP device (Cellular phones) is part of wireless network. WAP Device sends the WAP request to the WAP Gateway, which in turn translates WAP requests to WWW requests, so that the WAP client is able to submit requests to the Web server. After receiving the response from the HTTP Web Server, WAP Gateway translates Web responses into WAP understandable responses and sends it to the WAP Device.

WAP Gateway

WAP gateway acts as mediator between Cellular device and HTTP or HTTPS web server. WAP gateway route requests from the client (Cellular Phones) to an HTTP (or Web) server. The WAP gateway can be located either in a telecom network or in a computer network (ISP).

The HTTP Web Server

It receives the request from WAP Gateway and process the request than finally sends the output to the WAP Gateway than the gateway sends this information to the WAP device using its wireless network.

Features of WAP

WAP has many key features that are representative of what the WAP Forum claims the protocol to be:

- **Interoperability:** It is an open license and free standard. This will allow vendors to use it with their wireless products.
- **Scalability:** It supports many transport layer protocols with a wide range of hand held devices regardless of what wireless device is being used.
- **Extensibility:** It can accommodate any kind of new wireless devices that are developed and produced by various vendors.
- **Flexibility:** It is very flexible and is able to work well with many wireless applications.
- **Reusability:** It extends and adapts to existing Internet standards so that when the standard is further developed it can able to accept the newer standard.

WAP protocol

WAP is designed in a layered fashion so that it can be extensible, flexible, and scalable. As a result, the WAP protocol stack is divided into five layers.

- **Application Layer: Wireless Application Environment (WAE).** This layer is responsible for content development because it contains device specifications, and the programming languages, like WML and WML Script.
- **Session Layer: Wireless Session Protocol (WSP).** WSP has been designed by the WAP Forum to provide fast connection, suspension and reconnection.
- **Transaction Layer: Wireless Transaction Protocol (WTP).** The WTP runs on the top of a datagram service like User Datagram Protocol (UDP) and it is the part of the standard protocol suite of TCP/IP protocols used to provide a simplified protocol suitable for low bandwidth wireless stations.

- **Security Layer: Wireless Transport Layer Security (WTLS).** WTLS provides security features that are based upon the Transport Layer Security (TLS) protocol standard. It includes data integrity checks, privacy and authentication services.
- **Transport Layer: Wireless Datagram Protocol (WDP).** The WDP allows WAP to be bearer-independent by adapting the transport layer of the underlying bearer. The WDP presents a consistent data format to the higher layers of the WAP protocol stack.

WAP Applications

Specific areas of applications that are being expanded to include the support of WAP are in the following:

- Person to Person Messaging
- Voice and Fax Mail Notifications
- Unified Messaging
- Internet Email
- Prepayment
- Ringtones
- Mobile Commerce
- Mobile Banking
- Chat
- Information Services

Advantages of WAP

- It is a common standard for linking mobile devices to Internet
- Best standard for web browsing in mobile devices
- Provides a secure wireless connection
- Provides a way to implement new functionality
- Adapts new standards for the industry

Disadvantages of WAP

- It has less Bandwidth
- Less Connection Stability
- Small downloadable unit size
- Very few handsets support WAP
- WAP Standard is incomplete

WAP PUSH ARCHITECTURE:

The WAP Push architecture allows information to be sent to a client device without user request. It is based on client-server model. But there is no request generated by the client. The server transmits its content before the client's request. Push technology is always initiated by the server only. The Push technology is helpful to implement alerts and notifications.

The Push content is originated in a server that needs to be delivered to a mobile phone. The Push initiator (PI) contacts The Push proxy gateway (PPG) from the internet side and delivers content to the destination client. The PPG then forwards the content to the mobile network to be delivered to destination client. The internet side PPG protocol is called Push Access Protocol. The WAP side protocol is called over the air.

PUSH-PULL Based Data Acquisition:

There are 3 types of browsing content can be pushed to a WAP Browser. These are service indication (SI), service loading (SL) and cache operation (CO). Push SI provides the ability to push content to the user and notify them about e-mail, news, commercial offers and so on.

The PUSH SL provides the ability to push some content to the WAP device without user request. A PUSH SL contains a URL that refers to the Push content. After receiving the PUSH SL, the push content is automatically retrieved by the WAP device and is presented to the user. PUSH CO is responsible for storing of data in the WAP devices cache memory.

I-Mode

I-Mode, stands for Internet Mode is a micro browser technology that supports text, graphics, audio, and video for Web access. It was introduced in February 1999.

I-Mode is one of the most successful services offering wireless web browsing and e-mail services from mobile phones.

I-Mode provides packet-data transmission, which enables operators to charge their customers according to the volume of data transmitted.

WML (Wireless Mark-up Language)

WML is used to design applications that are sent over wireless devices such as mobile phones. This language takes care of the small screen and the low bandwidth of transmission. WML is an application of XML, which is defined in a document-type definition.

WML pages are called decks. They are constructed as a set of cards, related to each other with links. When a WML page is accessed from a mobile phone, all the cards in the page are downloaded from the WAP server to mobile phone.

WML commands and syntaxes are used to show contents, commands to declare variables, format text, and show images on the mobile phone

- WML stands for **Wireless Mark-up Language**
- WML is based on HDML (Handheld Device Mark-up Language) and is modified so that it can be compared with HTML.
- WML takes care of the small screen and the low bandwidth of transmission.
- WML is the mark-up language defined in the WAP specification.
- WAP sites are written in WML, while web sites are written in HTML.
- WML is very similar to HTML. Both of them use tags and are written in plain text format.
- WML files have the extension ".wml".
- WML supports client-side scripting. The scripting language supported is called WML Script.

WML Decks and Cards:

In HTML when we click “HYPER LINK” it will open another page but in case of WML this page is known as CARD. A WML file can contain multiple cards and the complete file is called deck.

When a WML page is accessed from a mobile phone, all the cards in the page are downloaded from the WAP server. So, if the user goes to another card of the same deck, the mobile browser does not have to send any requests to the server since the file that contains the deck is already stored in the wireless device.

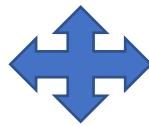

UNIT -9

GSM

GSM stands for **G**lobal **S**ystem for **M**obile **C**ommunication. It is a digital cellular technology used for transmitting mobile voice and data services. GSM is a globally accepted standard for digital cellular communications. GSM uses narrowband Time Division Multiple Access (TDMA) for providing voice and text-based services over mobile phone networks. GSM operates on the mobile communication bands 900 MHz and 1800 MHz in most parts of the world. GSM was developed using digital technology. It has an ability to carry 64 kbps to 120 Mbps of data rates. Presently GSM supports more than one billion mobile subscribers in more than 210 countries throughout the world.

GSM features

- Improved spectrum efficiency
- International roaming
- Low-cost mobile sets and base stations (BSs)
- High-quality speech
- Compatibility with Integrated Services Digital Network (ISDN) and another telephonic network.

GSM – Architecture

A GSM network comprises of many functional units. These functional units are:

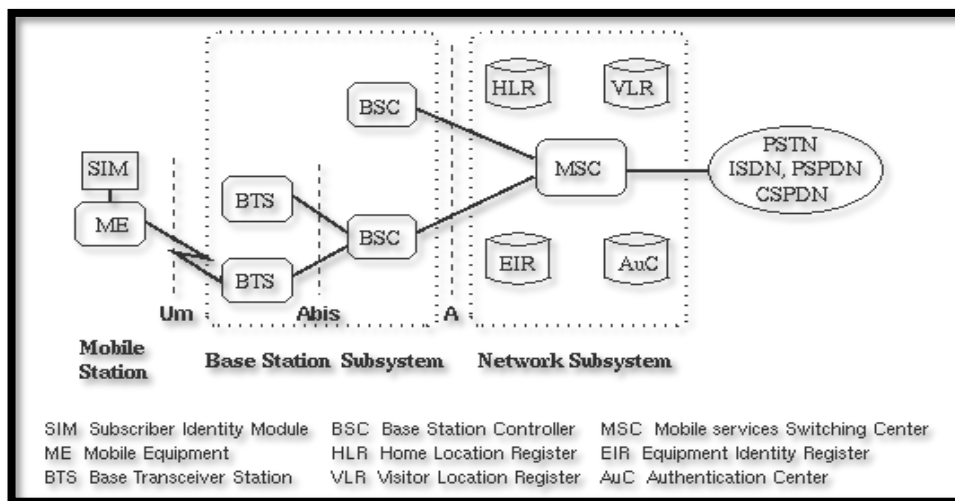

Mobile Station

The mobile station (MS) consists of

- **The mobile equipment (ME):** It is a portable device that can be used for voice communication. It is produced by many different manufacturers. It must be obtained approval from the standardization body. It is uniquely identified by an IMEI (International Mobile Equipment Identity).
- **The Subscriber Identity Module (SIM):** It is an intelligent card that holds service subscription information, identity, and personal information. The **SIM contains a microprocessor, memory and software to hold and process information** like a phone number, billing identification information and a small amount of user specific data

Base Station Subsystem

In the GSM network, the Base Station Subsystem (BSS) is the part of the network taking care of radio frequency resources, radio channel allocation and quality of the connection. It is composed of two parts.

1. **Base Transceiver Station (BTS):** The BTS is responsible for transmitting and receiving radio signals using a transceiver and it also minimizing the transmission problems.
2. **Base Station Controller (BSC):** The BSC is the central network component of the BSS and it controls the radio network. It has several important tasks like
 - Connection establishment between the MS and the NSS
 - Mobility management
 - Statistical raw data collection

Network Switching Subsystems (NSS)

It is the main part of the Mobile Switching Centre (MSC), which performs the switching of calls between the mobile and other fixed or mobile network users, as well as it manages the mobile services such as authentication.

The central component of the Network Subsystem is the Mobile services Switching Center (MSC).

Mobile Switching Center (MSC): The MSC performs the switching of calls between the mobile and other fixed or mobile network users, as well as the management of mobile services such as registration, authentication, location updating, handovers, and call routing to a roaming subscriber. The other components that are connected to MSC are:

- **Home Location Register (HLR):** It is a database used for storage and management of subscriptions. The HLR is the most important database, as it stores permanent data about subscribers, SIM registration, user profile, location information, and activity status.
- **Visitor Location Register (VLR):** The VLR is a database that contains temporary information about subscribers which is needed by the MSC in order to provide services to visiting subscribers.

The VLR is always integrated with the MSC. When a mobile station roams into a new MSC area, the VLR connected to that MSC and will request data about the mobile station from the HLR.

- **Authentication Center (AUC):** The authentication center (AuC) stores and processes information that is required to validate the identity ("authenticate") of a wireless telephone before the service is provided.
- **Equipment Identity Register (EIR):** It is a database that contains the identity of telecommunications devices and the status of these devices in the network. The EIR is mainly used to identify wireless telephones.

Call Setup in GSM

When a mobile subscriber makes a call to a PSTN telephone subscriber, the following sequence of events takes place:

- The MSC/VLR receives the message of a call request.
- The MSC/VLR checks if the mobile station is authorized to access the network. If so, the mobile station is activated. If the mobile station is not authorized, then the service will be denied.
- MSC/VLR analyses the number and initiates a call setup with the PSTN.
- MSC/VLR asks the corresponding BSC to allocate a traffic channel (a radio channel and a time slot).
- The BSC allocates the traffic channel and passes the information to the mobile station.
- The called party answers the call and the conversation takes place.

GPRS NETWORK

General Packet Radio System is also known as **GPRS** is a third-generation step toward internet access. GPRS is also known as GSM-IP that is a Global-System Mobile Communications Internet Protocol as it keeps the users of this system online, allows to make voice calls, and access internet on-the-go. Even Time-Division Multiple Access (TDMA) users benefit from this system as it provides packet radio access. In addition, GPRS allows improved quality of data services in terms of reliability, response time and features supported. GPRS also permits the network operators to execute an Internet Protocol (IP) based core architecture for integrated voice and data applications that will continue to be used and expanded for 3G services.

The GPRS specifications are written by the European Telecommunications Standard Institute (ETSI), the European counterpart of the American National Standard Institute (ANSI).

Key Features

Following three key features describe wireless packet data:

- **The always online feature** - Removes the dial-up process, making applications only one click away.
- **An upgrade to existing systems** - Operators do not have to replace their equipment; rather, GPRS is added on top of the existing infrastructure.
- **An integral part of future 3G systems** - GPRS is the packet data core network for 3G systems EDGE and WCDMA.

GPRS Architecture

GPRS architecture works on the same procedure like GSM network, but, has additional entities that allow packet data transmission. This data network overlaps a second-generation GSM network providing packet data transport at the rates from 9.6 to 171 kbps. Along with the packet data transport the GSM network accommodates multiple users to share the same air interface resources concurrently. Following is the GPRS Architecture diagram:

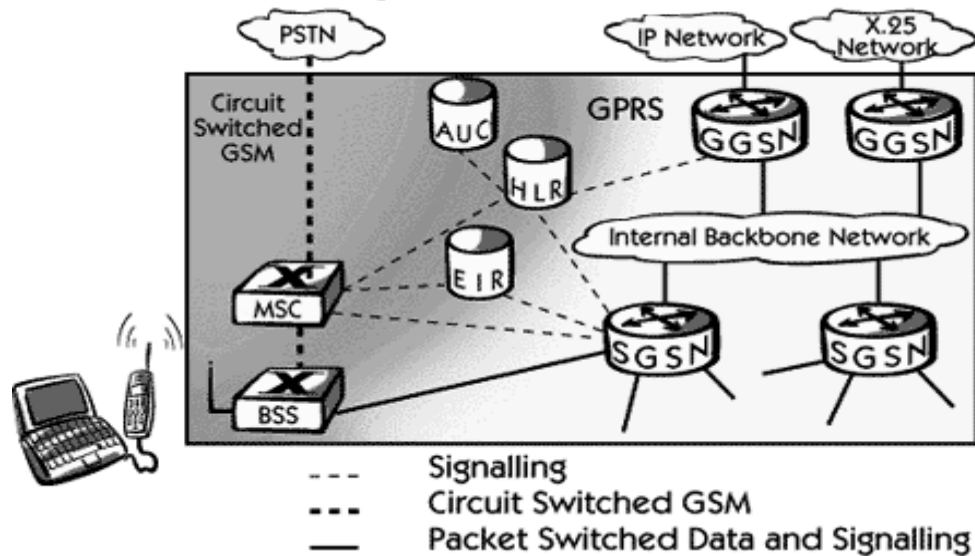

GPRS attempts to reuse the existing GSM network elements as much as possible, but to effectively build a packet-based mobile cellular network, some new network elements, interfaces, and protocols for handling packet traffic are required.

GPRS Mobile Stations

New Mobile Stations (MS) are required to use GPRS services because existing GSM phones do not handle the enhanced air interface or packet data. A variety of MS can exist, including a high-speed version of current phones to support high-speed data access, a new PDA device with an embedded GSM phone, and PC cards for laptop computers. These mobile stations are backward compatible for making voice calls using GSM.

GPRS Base Station Subsystem

Each BSC requires the installation of one or more Packet Control Units (PCUs) and a software upgrade. The PCU provides a physical and logical data interface to the Base Station Subsystem (BSS) for packet data traffic. The BTS can also require a software upgrade but typically does not require hardware enhancements. When either voice or data traffic is originated at the subscriber mobile, it is transported over the air interface to the BTS, and from the BTS to the BSC in the same way as a standard GSM call. However, at the output of the BSC, the traffic is separated; voice is sent to the Mobile Switching Center (MSC) per standard GSM, and data is sent to a new device called the SGSN via the PCU over a Frame Relay interface.

GPRS Support Nodes

Following two new components, called Gateway GPRS Support Nodes (GGSNs) and, Serving GPRS Support Node (SGSN) are added:

Gateway GPRS Support Node (GGSN)

The Gateway GPRS Support Node acts as an interface and a router to external networks. It contains routing information for GPRS mobiles, which is used to tunnel packets through the IP

based internal backbone to the correct Serving GPRS Support Node. The GGSN also collects charging information connected to the use of the external data networks and can act as a packet filter for incoming traffic.

Serving GPRS Support Node (SGSN)

The Serving GPRS Support Node is responsible for authentication of GPRS mobiles, registration of mobiles in the network, mobility management, and collecting information on charging for the use of the air interface.

Internal Backbone

The internal backbone is an IP based network used to carry packets between different GSNs. Tunnelling is used between SGSNs and GGSNs, so the internal backbone does not need any information about domains outside the GPRS network. Signalling from a GSN to a MSC, HLR or EIR is done using SS7.

Routing Area

GPRS introduces the concept of a Routing Area. This concept is similar to Location Area in GSM, except that it generally contains fewer cells. Because routing areas are smaller than location areas, less radio resources are used while broadcasting a page message.

GPRS - Network Processes

This chapter gives a brief description of the basic processes used in GPRS networks:

- **Attach process** - Process by which the MS (Mobile Stations) attaches (i.e., connects) to the SGSN in a GPRS network.
- **Authentication process** - Process by which the SGSN authenticates the mobile subscriber.
- **PDP activation process** - Process by which a user session is established between the MS and the destination network.
- **Detach process** - Process by which the MS detaches (i.e., disconnects) from the SGSN in the GPRS network.
- **Network-initiated PDP request for static IP address** - Process by which a call from the packet data network reaches the MS using a static IP address.
- **Network-initiated PDP request for dynamic IP address** - Process by which a call from the packet data network reaches the MS using a dynamic IP address.

GPRS Classes of Device

There are mainly 3 types of devices which can be used in GPRS technology. These are:

1. **Class A:** In this type the mobile station can operate simultaneous packet switch and circuit switch services. It means that MS can work both on GSM and GPRS network at a time. In other words, that a user can simultaneously make a voice call as well as the user can access internet. There are very few mobile devices of this class available in the market.

2. **Class B:** In this class MS can operate either one facility at a time. That means a user can either make a call or he/she can access internet in that mobile device. User cannot avail both the facilities at a time.
3. **Class C:** In this type of class a mobile device can handle only either voice or data. The user needs to switch on the facility manually. Example is Laptop.

GPRS technology offered some significant benefits are:

- **Speed:** The main benefits of GPRS technology is that it offers a much higher data transfer rate up to 172 kbps. But in most conditions, it transferring data between 15 - 40 kbps.
- **Packet switched operation:** GSM technology uses circuit switched techniques for data transmission but GPRS technology uses packet switching for data transmission. This makes more efficient use of the available capacity, and it allows greater combination with Internet techniques.
- **Always on connectivity:** A further advantage of GPRS is that it offers an "Always On" capability. When using circuit switched techniques, charges are based on the time a circuit is used, i.e., how long the call is. For packet switched technology charges are for the amount of data carried as this is what uses the services provider's capacity. Accordingly, always on connectivity is possible.
- **More applications:** The packet switched technology including the always on connectivity combined with the higher data rates opens up many more possibilities for new applications.

GPRS Application

Chat, Web Browsing, SMS/MMS, Image, E-mail

IS-95

It is known as Interim Standard 95 (IS-95) or CDMA (Code Division Multiple Access) technology. It is a second-generation (2G) digital mobile telephone standard used by CDMA.

CDMA is digital radio signal that transmits streams of bits and it permits to share the same Radio frequencies among several users.

CDMA spreads the signal over a wide bandwidth, identifying each channel using unique digital codes.

In CDMA, all users share the same 1,250 kHz wide carrier, but unique digital codes are used to differentiate subscribers. The codes are shared by both the mobile station and the base station.

IS-95 Architecture

The main components of IS-95 are as follows

- **Mobile Station (MS):** It is the stand-alone device i.e. the mobile phone with the user.
- **Base Station (BS):** it is the connection system between MS and MSC. It is divided into BTS & BSC.

- **Mobile Switching Centre (MSC):** It is the interface between wireless network and wired network. It handles the traffic between wireless & wired network. It is equivalent to a fixed telephone exchange.
- **Home Location Register (HLR):** It manages and stores the permanent data about subscribers, SIM registration, user profile, location information, and activity status.
- **Data Message Handler (DMH):** It is responsible for collecting billing data of the user.
- **Visited Location Register (VLR):** VLR is a database that contains temporary information about subscribers which is needed by the MSC. It is linked to one or more MSCs.
- **Authentication Centre (AuC):** It manages the authentication process of user. It may be located within HLR or MSC or it may be independent entity.
- **Equipment Identity Register (EIR):** It keeps the record of mobile device and provides to MSC when it requires.
- **Operation System (OS):** It is responsible for overall management of wireless network.
- **Internetworking Function (IWF):** It allows MSC to communicate with other network.
- **External Networks:** These are other networks like PSTN or ISDN.

CDMA 2000

CDMA2000 is a hybrid 2.5G / 3G technology of mobile telecommunications that use CDMA (code division multiple access) to send digital radio, voice, data, and signaling data between mobile phones and cell sites.

The cdma2000 network comprises three major parts: the core network (CN), the radio access network (RAN) and the mobile station (MS).

The core network is further decomposed in two parts, one interfacing to external networks such as the Public Switched Telephone Network (PSTN) and the other interfacing to the IP based network such as Internet.

Components of CDMA2000:

Base Transceiver System (BTS): It is an entity that provides transmission capabilities across the network. The BTS consists of radio devices, antenna and equipment.

Base Station Controller (BSC): It is a device that provides control and management for one or more BTSs.

Packet Control Function (PCF): It is an entity that provides interface function between the access network and the packet switched network.

WCDMA

- It stands for Wideband Code Division Multiple Access. It is a spread spectrum 3G CDMA mobile telecommunication technology.

- W-CDMA can be implemented by migrating via GPRS and EDGE on the 2G network infrastructure of the GSM standard
- W-CDMA allows transmission of signals for various services with variable data rates on 5 MHz bandwidths.
- It provides Increased Network Capacity and reduced cost of voice and data services.

Difference between CDMA & WCDMA

- The basic difference between the CDMA and WCDMA is bandwidth; CDMA uses 1.25 MHz frequency bandwidth while WCDMA uses 5 MHz bandwidth.
- Again, CDMA is 2g telecommunication standard and provide very less data rates compared to WCDMA which is third generation technology.
- CDMA being 2g standard provide mainly circuit switched services while WCDMA being used in UMTS system is used in both circuit switched and packet switched networks.

Wireless Sensor Network

- It is wireless network consisting of sensors to monitor the physical or environmental conditions like Temperature, Sound, Vibration Pressure, Pollutants at different locations.
- It is used in many areas like Environment Monitoring, Health Care Applications, Home automations and Traffic Control.
- A Sensor Network forms a network in ad-hoc mode. Several nodes may forward data packets to the base stations.
- Each node in sensor network equipped with radio transceiver and battery power.

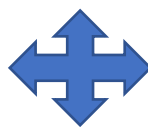

UNIT-10

SMS

Short message service (SMS) is a globally accepted wireless service that enables the transmission of alphanumeric messages between mobile subscribers and external systems such as electronic mail, paging, and voice mail systems. SMS text messaging supports various languages. Besides text, SMS messages can send ringtones, pictures, operator logos, wallpapers, animations, etc.

SMS provides a mechanism for transmitting "short" messages to and from wireless handsets. To provide this service it uses a short message service center (SMSC) which acts as a store and forward system for short messages.

The SMS features confirmation of message delivery. This means that, the sender of the short message can receive a return message back notifying them whether the message has been delivered or not.

Architecture of SMS

The figure below shows a typical organization of network elements in a GSM network supporting SMS.

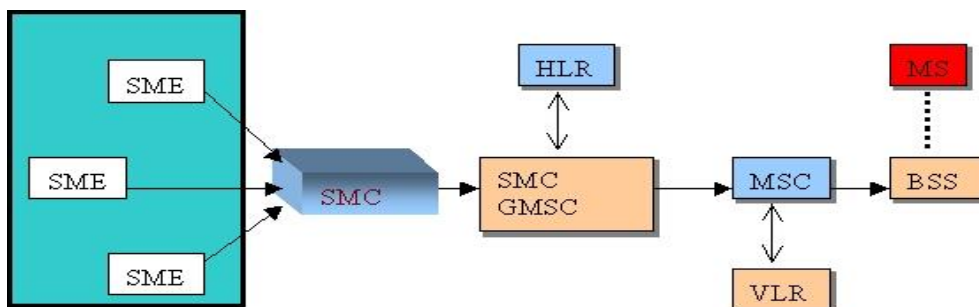

The SMC (Short Message Centre) is the entity which does the job of store and forward of messages to and from the mobile station.

The SME (Short Message Entity) which can be located in the fixed network or a mobile station receives and sends short messages.

The SMS GWMS (SMS gateway MSC) is a gateway MSC that can also receive short messages.

The gateway MSC is a mobile network's point of contact with other networks. On receiving the short message from the short message center, GMSC verifies the current position of the mobile station from the HLR, the home location register.

HLR is the main database in a mobile network. It holds information of the subscription profile of the mobile and also about the routing information for the subscriber, i.e., the area (covered by a MSC) where the mobile is currently situated. The GMSC is thus able to pass on the message to the correct MSC.

MSC (Mobile Switching Centre) is the entity in a GSM network which does the job of switching connections between mobile stations to other mobile stations or the fixed network.

A VLR (Visitor Location Register) corresponds to each MSC and contains temporary information about the mobile like mobile identification and the cell (or a group of cells) where the mobile is currently situated.

Using information from the VLR the MSC is able to switch the information (short message) to the corresponding BSS (Base Station System, BSC + BTSs), which transmits the short message to the mobile.

The BSS consists of transceivers, which send and receive information over the air interface, to and from the mobile station. This information is passed over the signaling channels so the mobile can receive messages even if a voice or data call is going on.

SMS Features

SMS has several unique features as mentioned below. SMS messaging uses the signaling layer, part of the communication channel, so it cannot support large amounts of data.

1. An SMS message content can be words of characters, numbers, or a combination of both and basic pictures or icons can also be attached in it. But the total length can be up to 160 characters.
2. SMS has store and forward feature. So mobile communication is not between two users but each message has to be routed through an intermediate referred to as SMSC.
3. When an SMS message is sent to one or more receivers, an acknowledgement is guaranteed.
4. Since SMS uses a separate signaling path rather than a dedicated radio channel, messages can be sent simultaneously with voice and data. So the users can send messages during peak hours without any interruptions
5. The telephone number of the sender of the message is automatically attached with the message itself. So, it is very easy for the receiver to know who the sender is.

MMS

The Multimedia Messaging Service (MMS) is the ability to send and receive messages comprising a combination of rich media including text, sounds, images and video to MMS capable handsets. MMS will be the first mobile messaging service to use the open Internet standards for messaging.

The industry standards governing MMS are defined and regulated by the industry bodies, WAP Forum and the 3G Partnership Project (3GPP).

MMS Architecture

The MMS architecture comprises the software messaging application in the MMS phone. This application is required for the composition, sending and retrieval of multimedia messages. In

addition, other elements are required to route messages, to receive content of messages and so on. The figure shows the general architecture of elements required for the MMS service.

The MMS client (also known as MMS user agent in the 3GPP terminology) is the software application which is within the mobile handset that allows the composition, viewing, sending, retrieval of multimedia messages and the management of reports.

For the exchange of a multimedia message, the MMS client that generates and sends the multimedia message is known as the originator MMS client, whereas the MMS client that receives the multimedia message is known as the recipient MMS client.

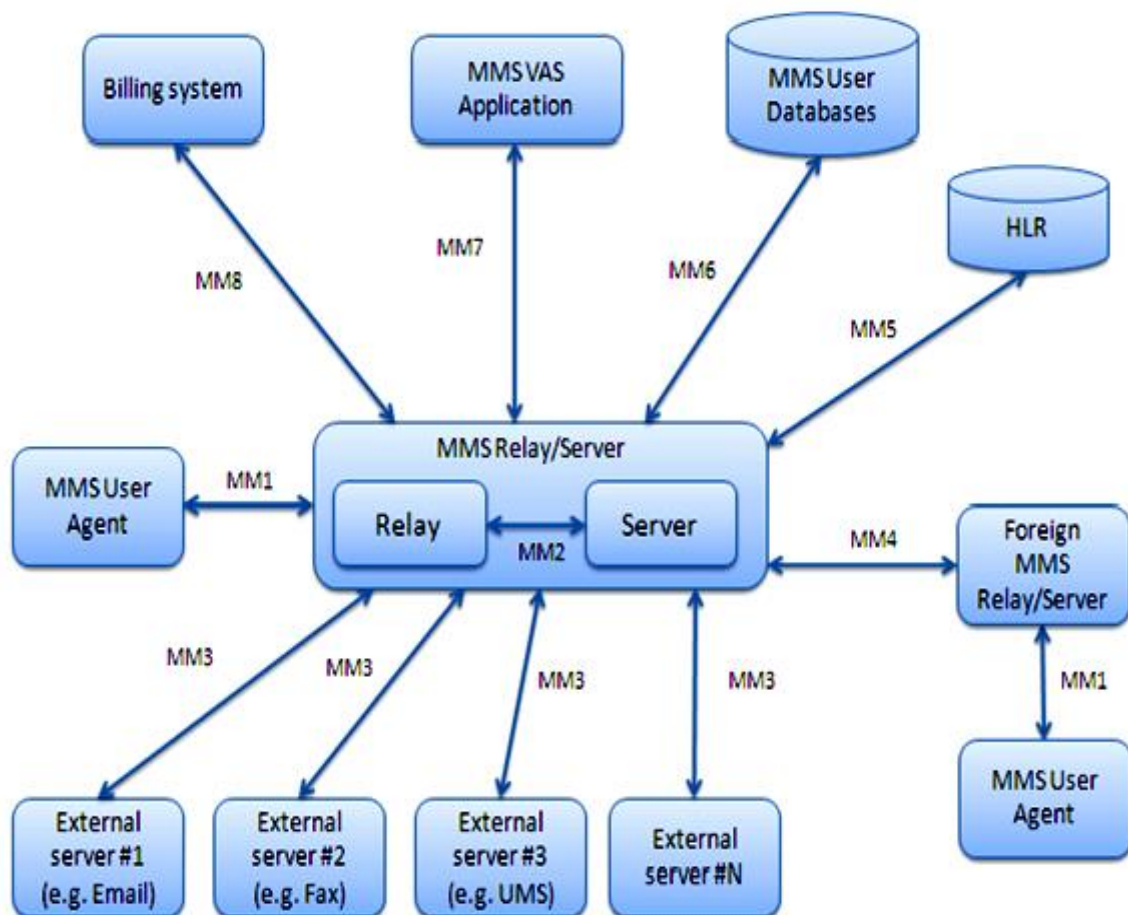

The main components of MMS architecture

The industry body, 3GPP, has defined four key functional elements of an MMSC product:

- **MMS Relay** - the engine which transcodes and delivers messages to mobile subscribers
- **MMS Server** – IT uses the store-and-forward technique and sends the message to the destination
- **MMS User Agent** - an application server giving users the ability to view, create, send, edit, delete and manage their multimedia messages

- **MMS User Databases** - containing records of user profiles, subscription data etc
- **MM1:** It is the interface between MMS User Agent and MMS Center (MMSC, the combination of the MMS Relay & Server)
- **MM2:** the interface between MMS Relay and MMS Server
- **MM3:** the interface between MMSC and other messaging systems. Using SMTP.
- **MM4:** the interface between MMSC. Using SMTP
- **MM5:** the interface between MMSC and HLR
- **MM6:** the interface between MMSC and user databases
- **MM7:** the interface between MMS VAS applications and MMSC
- **MM8:** the interface between MMSC and the billing systems
- **MM9:** the interface between MMSC and an online charging system
- **MM10:** the interface between MMSC and a message service control function
- **MM11:** the interface between MMSC and an external transcoder

Multimedia Transmission over Wireless

It is basically the handoff process of mobile device. We are accessing video streaming, audio streaming in our mobile devices like mobile hand Set, PDA or Laptop while moving or roaming.

User will get the live streaming while roaming in the Home Network and there is no problem. But it is not possible to maintain the live steaming in mobile device while moving from one network to other network because IP protocol does not allow maintaining the continuity of the network.

It will discontinue the link from the Home Network and will connect the Visitors Network. So it is loss of data and live streaming.

So Mobile IP (MIP) is using to avoid this problem. Mobile IP extends its support to existing IP protocol for Host Mobility, and Handoff process by using Home Agent (HA) and Foreign Agent (FA) network entities.

Bothe these entities HA and FA work together for the user mobility. In this way the Mobile user will move from own network to other network without losing the network connection.

