

JHARSUGUDA ENGINEERING SCHOOL **JHARSUGUDA**



ANALOG & DIGITAL COMMUNICATION LAB MANUAL

**Prepared by,
GANESH MAHANTA**

Year & Semester: 3RD Year, 5TH Semester

Subject code/Name: Pr-1 Analog & Digital Communication Lab

**DEPARTMENT OF ELECTRONICS AND TELECOMMUNICATION
ENGINEERING**

VISION OF THE DEPARTMENT:-

To contribute in the nation development in the field of Electronics and Telecommunication by imparting quality education, promoting academic achievement to produce internationally accepted high quality human and technological resource for the country.

MISSION OF THE DEPARTMENT

- 1 To prepare students for a brilliant career/entrepreneurship along with the development of the knowledge, skills, attitude and teamwork through the designed programme.
2. To impart quality teaching-learning experience with state of the art curriculum.
3. To undertake collaborative projects which offer opportunities for long term interaction with academia and industry. Sustained interaction with the alumni, students, parents, faculty and other stake holders.
4. To develop human potential to its fullest extent so that intellectually capable and imaginative gifted leaders can emerge in a range of professions.

PROGRAM EDUCATIONAL OBJECTIVE:-

1. To impart analytic and thinking skills to develop initiatives and innovative ideas for R&D, Industry and societal requirements.
2. To understand the facets of advanced technologies, processes and materials necessary in the engineering field.
3. To provide sound theoretical and practical knowledge of E&C Engineering, managerial and entrepreneurial skills to enable students to contribute to sustenance of society with a global outlook.
4. To inculcate qualities of teamwork, good social, interpersonal and leadership skills and an ability to adapt to evolving professional environments in the domains of engineering and technology.
5. To appreciate the significance of collaborations in designing, planning, and implementing solutions for practical problems and facilitate the networking with national research and academic organization

CONTENTS

Sl no	LIST OF EXPERIMENT	PAGE NO
1	Study the Antenna Trainer for different type of Antenna & find its gain Equipment Required:	04-05
2	Draw the radiation pattern & find the characteristics of antenna (Yagi,Horn,,Rombus,Dipole)	06-07
3	Draw the waveform of different lobe of different Antenna using antenna trainer. Materials and Equipment:	08-11
4	Find the Standing Wave ratio (Open & Short Circuit) & different losses in Transmission line.	12—14
5	To study different types of Microwave components Equipment Required	15-17
6	Measure VSWR of different type of load (Matched ,Open ,Shorted)using microwave test bench.	18-20
7	Measurement of microwave power using power meter.	21-22
8	Set up & installation of Dish TV .	23-25
9	To Study the SMPS section and find out load & line regulation	26-28
10	Study the basic common faults in LED TV	29-31

Aim of the experiment:

Study the Antenna Trainer for different type of Antenna & find its gain

Equipment Required:

1. Antenna Trainer with various antenna elements (e.g., dipole, yagi, patch, helical, etc.)
2. Signal generator
3. RF power meter
4. Coaxial cables
5. SWR meter
6. Measuring tape
7. Height-adjustable stand
8. Antenna analyzer or network analyzer (optional)

Theory:

Antenna gain is a measure of how well an antenna focuses its power in a specific direction compared to an ideal isotropic radiator. It is usually expressed in decibels (dBi or dBd). The gain of an antenna is a crucial factor in determining its effectiveness in transmitting or receiving signals.



DIFFERENT TYPE OF ANTENNA

Procedure:

Setup:

- a. Set up the antenna trainer on a sturdy, non-metallic surface.
- b. Connect the signal generator to the antenna trainer using a coaxial cable.
- c. Connect the RF power meter to the antenna trainer using another coaxial cable.

EXPERIMENT NO-02

AIM OF THE EXPERIMENT:-

Draw the radiation pattern & find the characteristics of antenna
(Yagi,Horn,,Rombus,Dipole)

EQUIPMENT REQUIRED:

1. Yagi antenna
2. Horn antenna
3. Rhombus antenna
4. Dipole antenna
5. Signal generator
6. RF spectrum analyzer
7. Rotating antenna mount
8. Coaxial cables
9. Power supply
10. Measurement instruments (e.g., rulers, protractors)
11. Graph paper or antenna measurement software
12. Data recording materials (notebook, pen)

THEORY:-

- Radiation Pattern: The radiation pattern of an antenna describes how it radiates or receives electromagnetic waves in space. It is typically represented as a graphical plot showing the antenna's gain or radiation intensity as a function of direction.

- Gain: Gain measures the antenna's ability to direct electromagnetic energy in a particular direction. It's usually measured in decibels (dBi).

Diagram:

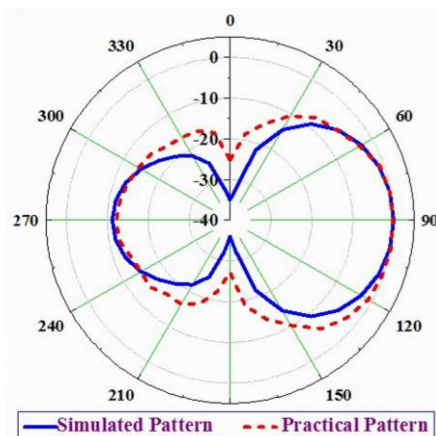

(RADIATION PATTERN OF YOGI ANTENNA)

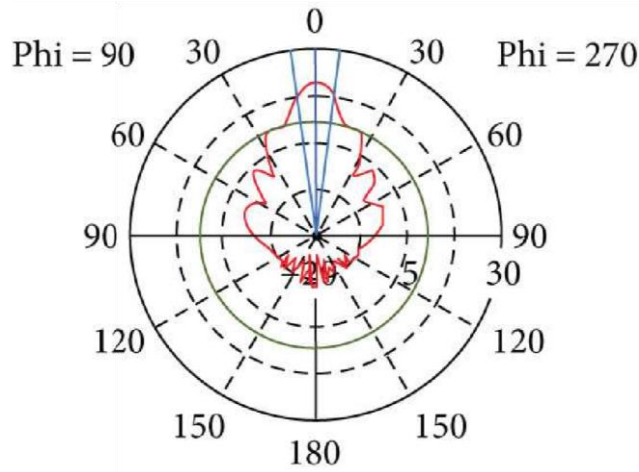

(RADIATION PATTERN OF HORN ANTENNA)

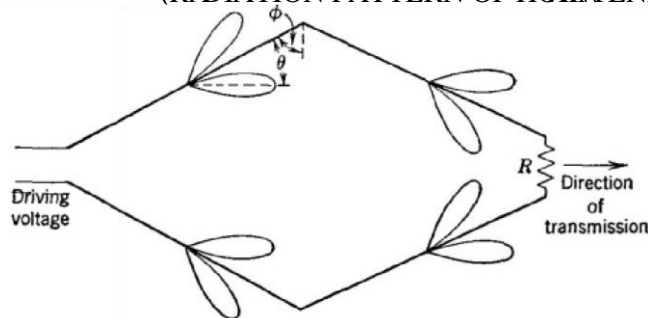

(RADIATION PATTERN OF RHOMBUS ANTENNA)

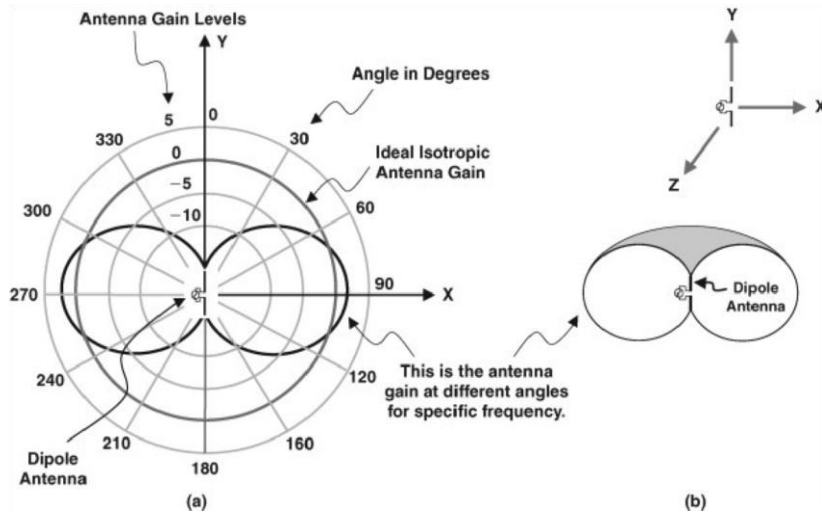

(RADIATION PATTERN OF DIPOLE ANTENNA)

PROCEDURE:

1. Setup:

- Set up the signal generator, RF spectrum analyzer, and power supply according to manufacturer instructions.
- Connect each antenna type to the RF spectrum analyzer using coaxial cables.

2. Calibration:

- Calibrate the RF spectrum analyzer for accurate measurements.

3. Radiation Pattern Measurement:

- Place each antenna on a rotating antenna mount.
- Ensure that the antennas are at the same height and distance from the RF spectrum analyzer.
 - Start with one antenna (e.g., Yagi):
- a. Rotate the antenna mount 360 degrees, taking radiation measurements at regular intervals (e.g., every 10 degrees).
- b. Record the measurements of signal strength for each angle.
 - Repeat the above steps for all antenna types.

4. Data Analysis:

- Plot the radiation patterns for each antenna type using the collected data. You can either use graph paper and draw by hand or use antenna measurement software if available.
- Calculate the gain for each antenna type based on the measured data.

5. Characteristics Comparison:

- Create a table to compare the characteristics of each antenna, including gain, directivity, and any notable features.

TABULATION:

Angle (degrees)	Yagi Antenna (dB)	Horn Antenna (dB)	Rhombus Antenna (dB)	Dipole Antenna (dB)

CONCLUSION:

From this above experiment we have studied to draw the radiation pattern & find the characteristics of antenna (Yagi, Horn, Rhombus, Dipole).

EXPERIMENT NO - 3

AIM OF THE EXPERIMENT:-

Draw the waveform of different lobe of different Antenna using antenna trainer.

EQUIPMENT REQUIRED:-

1. Antenna trainer kit
2. Antennas with different characteristics (e.g., dipole, Yagi-Uda, parabolic dish)
3. Signal generator
4. Oscilloscope or spectrum analyzer
5. Coaxial cables
6. Power supply
7. Waveform drawing tools (e.g., paper and pens)

THEORY:-

1. Antenna Radiation Patterns:

Antennas are devices that transmit and receive electromagnetic waves.

The radiation pattern of an antenna describes how the antenna radiates energy into space or captures energy from space.

Radiation patterns are typically represented in both azimuth (horizontal) and elevation (vertical) planes.

2. Main Lobe:

The main lobe is the primary direction in which an antenna radiates or receives the majority of its energy.

It is the region where the antenna has the highest gain and the most significant directivity.

The width of the main lobe is defined by the antenna's beamwidth, which is usually measured in degrees.

3. Side Lobes:

Side lobes are additional lobes in the radiation pattern that are not the main lobe.

Side lobes are usually weaker than the main lobe but still contribute to the antenna's radiation in directions other than the main lobe.

The presence and strength of side lobes depend on the antenna's design and can vary significantly between different antenna types.

4. Nulls:

Nulls are regions in the radiation pattern where the antenna's radiation is minimal or nearly zero.

Nulls are often observed between the main lobe and side lobes and can be important for antenna applications where interference rejection is crucial.

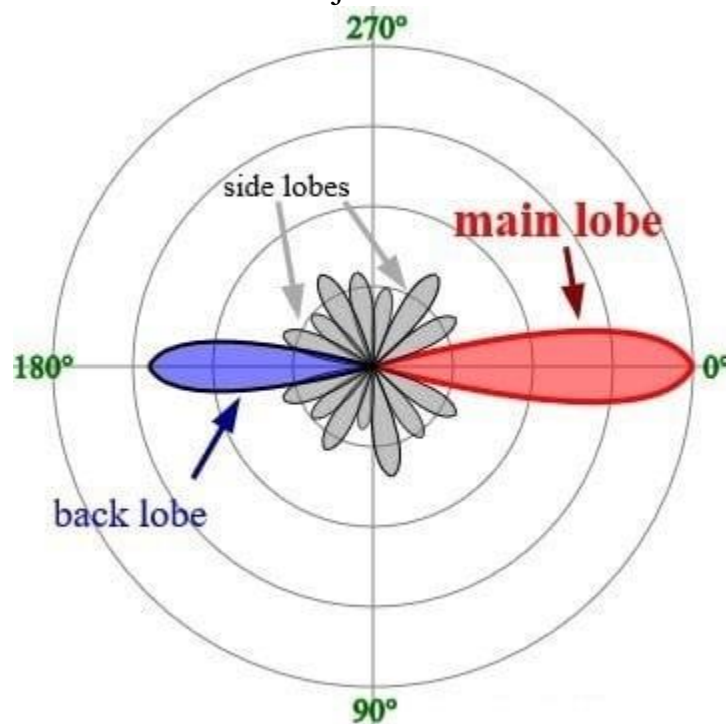

PROCEDURE:

Setup

Equipment:

- Set up the antenna trainer kit in a laboratory or controlled environment.
- Connect the signal generator to the antenna trainer kit using a coaxial cable.
- Connect the oscilloscope or spectrum analyzer to the antenna trainer kit to visualize the waveforms.
- Ensure that the power supply for the antenna trainer kit is connected and operational.

Select Antennas:

- Choose the antennas you want to experiment with. You can select antennas with different designs and characteristics to observe various types of lobes (e.g., directional, omnidirectional).
- Mount the selected antennas on the antenna trainer kit according to the manufacturer's instructions.

Configure Signal Generator:

- Set the signal generator to generate the desired frequency and amplitude for the experiment.
- Ensure that the signal generator is synchronized with the oscilloscope or spectrum analyzer.

Collect Data:

- Activate the signal generator to transmit signals through the antennas.
- Use the oscilloscope or spectrum analyzer to capture the waveforms generated by the antennas.
- Adjust the frequency and amplitude as needed to observe different lobe patterns.

Record Observations:

- Record the waveform patterns displayed on the oscilloscope or spectrum analyzer for each antenna.
- Note any differences in the lobes, including main lobes, side lobes, and nulls.
- Measure and record relevant parameters such as beamwidth and gain for each antenna.

Waveform Drawing:

- Based on the observations and measurements, draw the waveforms of the different lobes for each antenna on a piece of paper or using digital drawing tools.
- Clearly label the main lobes, side lobes, and nulls on your waveform drawings.

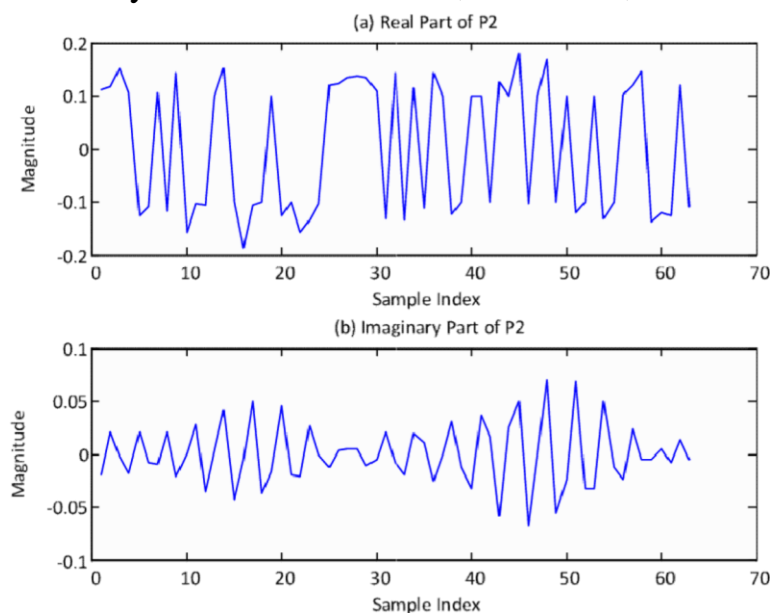

Conclusion:

EXPERIMENT NO-04

AIM OF THE EXPERIMENT:-

Find the Standing Wave ratio (Open & Short Circuit) & different losses in Transmission line.

EQUIPMENT REQUIRED:

1. Coaxial transmission line (e.g., RG-58)
2. Signal generator
3. Oscilloscope
4. Load resistors (50Ω)
5. Short circuit termination (shorting plug)
6. Open circuit termination (BNC T-connector with one end terminated)
7. BNC cables and connectors
8. Multimeter
9. Power supply (if required)

THEORY:

When an electrical signal travels through a transmission line, it can encounter impedance mismatches at the source and load ends, causing reflections. The Standing Wave Ratio (SWR) quantifies the extent of these reflections and helps assess how well a transmission line is matched to the source and load impedances. Losses in a transmission line can occur due to conductor resistance, dielectric loss, and mismatched terminations.

PROCEDURE:

1. Connect the signal generator's output to the input of the transmission line using a BNC cable.
2. Connect the load resistor (50Ω) to the far end of the transmission line using a BNC cable.
3. Ensure that the transmission line is properly terminated with the 50Ω load resistor.
4. Power on the signal generator, set it to produce a known frequency (e.g., 1 MHz), and adjust the output power.
5. Measure the forward voltage (V_f) and the reflected voltage (V_r) at the input end of the transmission line using the oscilloscope. Ensure proper calibration.
6. Calculate the Standing Wave Ratio (SWR) using the formula: $SWR = (1 + \sqrt{V_r/V_f}) / (1 - \sqrt{V_r/V_f})$
7. Record the SWR value in a table.
8. Replace the 50Ω load resistor with a short circuit termination (shorting plug).
9. Repeat steps 5 and 6 to measure the SWR for the short circuit termination.
10. Replace the short circuit termination with an open circuit termination (BNC T-connector with one end terminated).
11. Repeat steps 5 and 6 to measure the SWR for the open circuit termination.

12. Calculate the Return Loss (RL) in dB for each case using the formula:

$$RL \text{ (dB)} = -20 * \log_{10}(\sqrt{V_r/V_f})$$

13. Record the RL values in the table.

14. Measure the input voltage and current at the source end using a multimeter.

15. Calculate the real and apparent power at the source.

16. Calculate the transmission line loss (in dB) for each case using the formula:

$$\text{Loss (dB)} = 10 * \log_{10}(V_f^2 / V_r^2)$$

17. Record the loss values in the table.

CIRCUIT DIAGRAM:

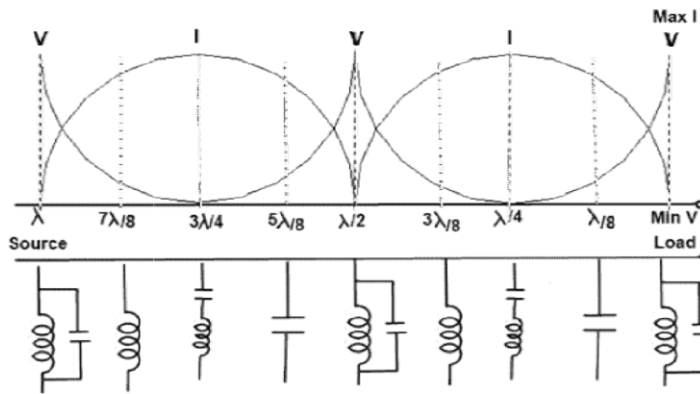

(OPEN CIRCUIED TRANSMISSION LINE)

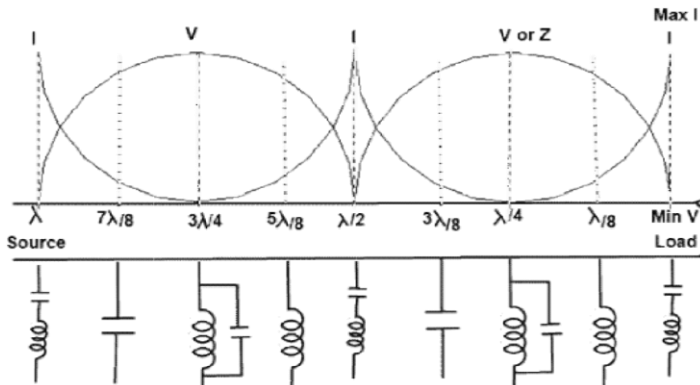

(SHORT CIRCUIED TRANSMISSION LINE)

TABULATION:

Termination Type	SWR	Return Loss (RL) (dB)	Loss (dB)
Loss (dB)			
Short Circuit			
Open Circuit			

CONCLUSION:

From this above experiment we have studied to find the Standing Wave ratio (Open & Short Circuit) & different losses in Transmission line.

EXPERIMENT NO-05

AIM OF THE EXPERIMENT:

To study different types of Microwave components

Equipment Required:

1. Microwave source (e.g., microwave generator)
2. Waveguide components (e.g., waveguide sections, bends, tees)
3. Antenna (e.g., horn antenna or dipole antenna)
4. Attenuators (e.g., fixed and variable attenuators)
5. Power meter
6. Frequency meter
7. Coaxial cables
8. Waveguide mounts and fixtures
9. Connecting adapters
10. Microwave absorbers
11. Screwdriver and wrenches

THEORY:

1. Waveguides: Microwave waveguides are hollow metal tubes or rectangular channels used to guide and manipulate microwave signals. They come in various shapes and sizes, and each type has unique characteristics. Waveguides are typically used for transmitting and receiving microwave signals with low loss and minimal interference.

2. Antennas: Antennas are devices that radiate or receive electromagnetic waves. In the context of microwaves, horn antennas and dipole antennas are commonly used. Antennas play a crucial role in the transmission and reception of microwave signals.

3. Attenuators: Attenuators are used to reduce the power level of microwave signals. Fixed attenuators provide a fixed level of attenuation, while variable attenuators allow adjustable attenuation. These components are essential for controlling signal power levels.

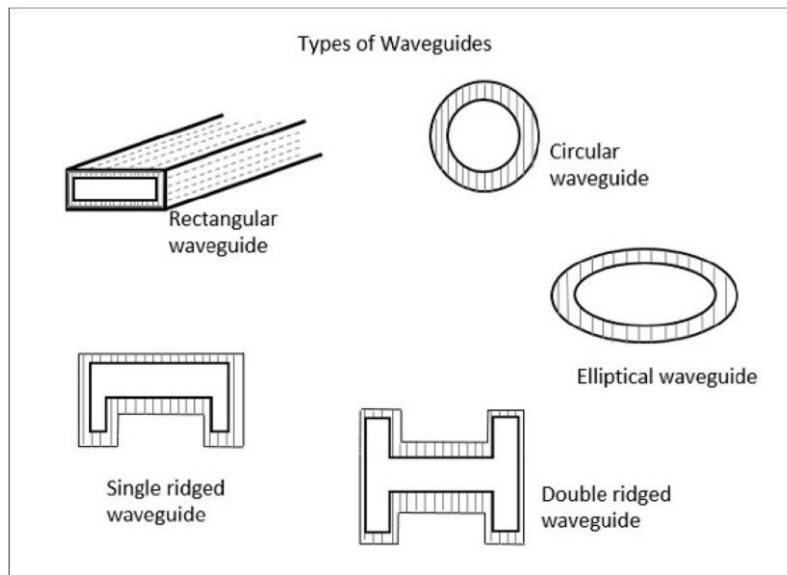

DIFFRENTS TYPES OF MICROWAVE COMPONENTS

PROCEDURE:

Setting Up the Experiment:

- a. Connect the microwave source to the power meter using coaxial cables.
- b. Connect the power meter to the waveguide component under study (e.g., a waveguide section or bend).
- c. Connect the waveguide component to the antenna.
- d. Connect the antenna to the frequency meter.
- e. Ensure all connections are secure.

Calibrating the System:

- a. Turn on the microwave source and set it to a specific frequency.
- b. Measure the initial power output using the power meter.

Waveguide Study:

- a. Replace different waveguide components (sections, bends, tees) and note any changes in signal characteristics.
- b. Record the frequency, power output, and any observations for each component.

Antenna Study:

- a. Replace the antenna with different types (horn antenna, dipole antenna).
- b. Record the frequency, power output, and any observations for each antenna.

Attenuator Study:

- a. Introduce fixed and variable attenuators into the setup.
- b. Measure the power output with different attenuation levels.
- c. Record the attenuation level, frequency, power output, and any observations.

Observation Table:

Component Type	Frequency (GHz)	Power Output (Db m)	Observations
Waveguide Section			
Waveguide Bend			
Antenna Type 1			
Antenna Type 2			
Fixed Attenuator			
Variable Attenuator			

Conclusion:

EXPERIMENT NO-06

Aim of the experiment:

Measure VSWR of different type of load (Matched ,Open ,Shorted)using microwave test bench.

Materials and Equipment:

1. Microwave test bench or Vector Network Analyzer (VNA)
2. Coaxial cables
3. Various loads (matched load, open circuit, short circuit)
4. Adapters and connectors as needed
5. Calibration kit for VNA (including calibration standards and standards holder) 6. Computer with VNA software (if not included with the VNA)

Theory:

1. VSWR (Voltage Standing Wave Ratio):

VSWR is a dimensionless ratio that describes the quality of the impedance match between a transmission line (or component) and its connected load. It is typically represented as $VSWR = (1 + \Gamma) / (1 - \Gamma)$, where Γ (Gamma) is the reflection coefficient.

2. Reflection Coefficient (Γ):

The reflection coefficient, Γ , quantifies the magnitude and phase of the reflected wave at the load. It is defined as the ratio of the amplitude of the reflected wave to the amplitude of the incident wave. $\Gamma = (V_{-} / V_{+})$, where V_{-} is the voltage of the reflected wave, and V_{+} is the voltage of the incident wave.

3. Significance of VSWR Measurement:

A VSWR of 1 ($VSWR = 1$) indicates a perfect impedance match between the transmission line and the load, meaning all power is transmitted with no reflection. This is typically the desired condition. A higher VSWR (>1) indicates an impedance mismatch, which results in partial power reflection back to the source.

A lower VSWR (<1) implies an unusual situation where power is drawn from the load into the transmission line.

4. Types of Loads and Their VSWR:

Matched Load:

A matched load is one where the impedance of the load matches the characteristic impedance of the transmission line (typically 50 or 75 ohms for RF applications).

In this case, $\Gamma = 0$, resulting in $VSWR = 1$.

This indicates that all incident power is absorbed by the load with no reflection, representing the ideal scenario.

Open Circuit Load:

An open circuit load occurs when the load impedance is much higher than the characteristic impedance of the transmission line.

In this case, most of the incident power is reflected back towards the source. This results in a high VSWR, typically much greater than 1.

Short Circuit Load:

A short circuit load happens when the load impedance is much lower than the characteristic impedance of the transmission line.

Similar to an open circuit load, most of the incident power is reflected back towards the source. This also leads to a high VSWR.

Procedure:

Setup and Calibration:

- a. Ensure that the microwave test bench or VNA is properly connected to a power source and turned on.
- b. Connect the calibration kit to the VNA's test port(s).
- c. Follow the manufacturer's instructions for performing a calibration. This usually involves connecting the open, short, and matched load standards from the calibration kit and performing a full 2-port calibration. Calibrating the VNA is crucial to obtain accurate measurements.

Connect the Load:

- a. Begin with the matched load. Connect it to one end of a coaxial cable.
- b. Connect the other end of the coaxial cable to the VNA's test port.
- c. Make sure all connections are secure.

Measure VSWR for the Matched Load:

- a. Open the VNA software on your computer if it's not integrated with the VNA hardware.
- b. Configure the VNA to measure S-parameters in the frequency range of interest. Choose an appropriate frequency range for your experiment.
- c. Measure the VSWR for the matched load by selecting the "S11" parameter (reflection coefficient at Port 1).
- d. Record the VSWR value and the corresponding frequency in your lab notebook.

Repeat for Open and Shorted Loads:

- a. Disconnect the matched load from the coaxial cable and replace it with an open circuit.
- b. Repeat the measurement process for the open circuit load, recording the VSWR value and frequency.
- c. Disconnect the open circuit load and replace it with a short circuit.

d. Repeat the measurement process for the short circuit load, recording the VSWR value and frequency.

A matched load should ideally have a VSWR of 1 (perfect match).

An open circuit load will typically have a high

VSWR. A short circuit load will also typically have a high VSWR.

c. Analyze how the VSWR changes with frequency, if applicable.

VSWR measurement block diagram

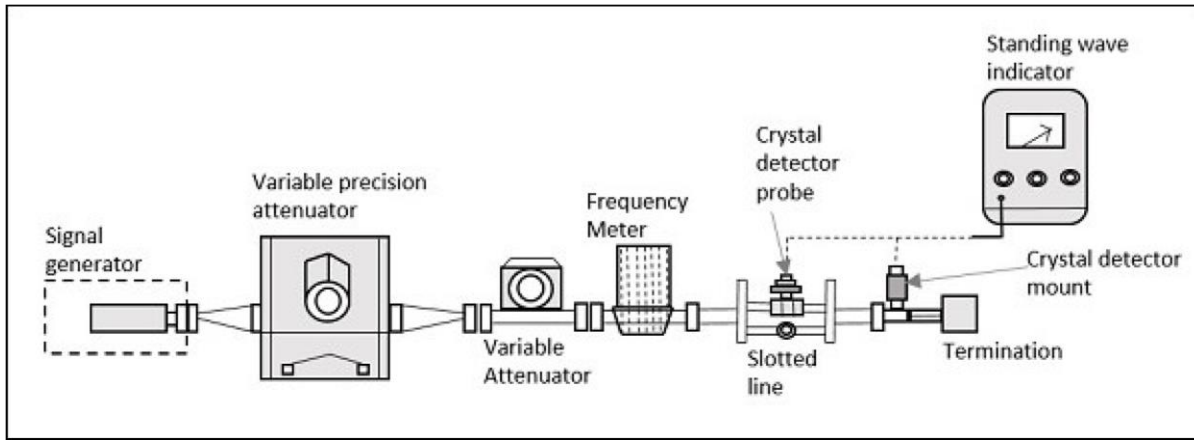

Conclusio

EXPERIMENT NO-07

AIM: Measurement of microwave power using power meter.

EQUIPMENT REQUIRED:

1. Microwave Source
2. Power Meter
3. Coaxial Cable
4. Waveguide or Horn Antenna
5. Microwave Absorber or Load
6. Microwave Detector (optional, if not built into the power meter)
7. Microwave Frequency Counter (optional, for frequency measurement)

THEORY:

Microwave power can be measured using a power meter, which is designed to accurately quantify the electromagnetic power at microwave frequencies. The power meter is typically calibrated to provide power measurements in Watts (W) or decibels (dBm).

The basic principle behind this measurement is to direct the microwave radiation from the source through a waveguide or horn antenna into the power meter. The power meter absorbs the microwave energy and converts it into an electrical signal. This electrical signal is then displayed as power on the meter's screen.

PROCEDURE:

1. Setup:

- a. Ensure that all equipment is properly connected and powered on.
- b. Connect the coaxial cable to the microwave source's output port.
- c. Connect the other end of the coaxial cable to the input of the waveguide or horn antenna.
- d. Place the waveguide or horn antenna in front of the power meter's detector.

2. Measurement :

- a. Turn on the microwave source and set it to the desired power level and frequency.
- b. Direct the microwave radiation from the source into the waveguide or horn antenna.
- c. Ensure that the power meter's detector is properly aligned with the microwave radiation.
- d. Observe and record the power measurement displayed on the power meter.

3. Repeat Measurements:

- a. Repeat the measurement at different power levels or frequencies, if necessary.
- b. Ensure that the power meter is allowed to stabilize between measurements.

DIAGRAM:

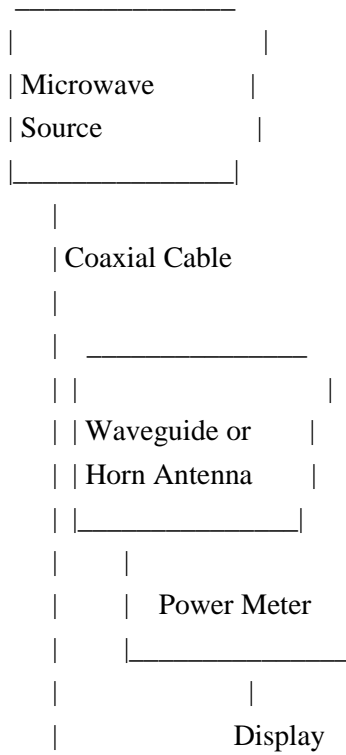

TABULATION:

Power Level (dBm)	Power Level (Watts)

CONCLUSION:

From this above experiment we have studied to measurement of microwave power using power meter.

EXPERIMENT NO-08

AIM: Set up & installation of Dish TV .

EQUIPMENT REQUIRED:

1. Dish TV satellite dish and LNB (Low Noise Block downconverter)
2. Satellite signal meter or satellite finder tool
3. Satellite coaxial cable
4. Satellite receiver box
5. TV and TV remote control
6. Mounting bracket and screws
7. Wrench and screwdriver
8. Compass
9. Signal strength chart (provided by Dish TV)

THEORY:

Satellite television relies on the transmission of television signals from a geostationary satellite to a satellite dish (receiver) located at the subscriber's premises. The satellite dish collects these signals and directs them to the LNB (Low Noise Block downconverter), which amplifies and downconverts the signals for reception by the satellite receiver. The receiver then decodes and displays the television channels on the connected TV.

PROCEDURE:

1. Select Installation Location:

- Choose an open area with a clear line of sight to the southern sky, where the satellite signals are strongest.
- Mount the bracket securely on a wall or roof, ensuring it's level and facing south.

2. Mount the Dish:

- Attach the satellite dish to the bracket using the provided screws and a wrench. Ensure it is securely fastened.
- Use a compass to ensure the dish is accurately pointing south (azimuth angle).

3. Connect the LNB:

- Attach the LNB to the arm of the satellite dish.
- Connect the coaxial cable to the LNB output.

4. Connect the Receiver:

- Connect the other end of the coaxial cable to the input on the satellite receiver.
- Connect the satellite receiver to the TV using appropriate cables (HDMI, RCA, etc.).

5. Power Up and Align:

- Power on the TV, satellite receiver, and satellite signal meter.
- Access the satellite signal meter's menu to monitor signal strength and quality.

6. Align the Dish:

- Slowly adjust the azimuth and elevation angles of the satellite dish while monitoring the signal meter.
- Aim for the highest signal strength and quality.
- Tighten all screws once the optimal signal is achieved.

7. Receiver Setup:

- Follow the on-screen instructions to set up the satellite receiver. This may involve entering your Dish TV account details and activating the service.

8. Channel Test:

- Tune the TV to a known channel to verify successful installation.

DIAGRAM:

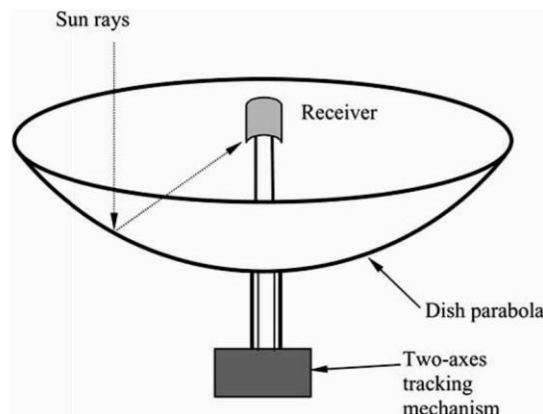

(DISHB ANTENNA)



(LNB RECEIVER)



(SIGNAL METER)

TABULATION:

Parameter	Measurement
Azimuth Angle	
Elevation Angle	
Signal Strength (dB)	
Signal Quality (%)	

CONCLUSION:

From this above experiment we have studied to set up & installation of Dish TV.

EXPERIMENT NO-09

Aim of the experiment:

To Study the SMPS section and find out load & line regulation.

Equipment Required:

1. SMPS unit
2. DC load resistor
3. Multimeter (for voltage measurements)
4. Power supply (for line regulation testing)
5. Connecting wires

Theory:

Switched-Mode Power Supplies (SMPS) are electronic circuits used to convert electrical power efficiently from one voltage level to another. Load regulation and line regulation are crucial parameters to evaluate the performance of an SMPS:

Load Regulation: Load regulation measures the ability of the SMPS to maintain a stable output voltage when the load (connected devices) varies. It is expressed as a percentage change in output voltage for a specified load change.

Line Regulation: Line regulation assesses the ability of the SMPS to maintain a consistent output voltage when the input voltage (line voltage) fluctuates. It is expressed as a percentage change in output voltage for a specified change in input voltage.

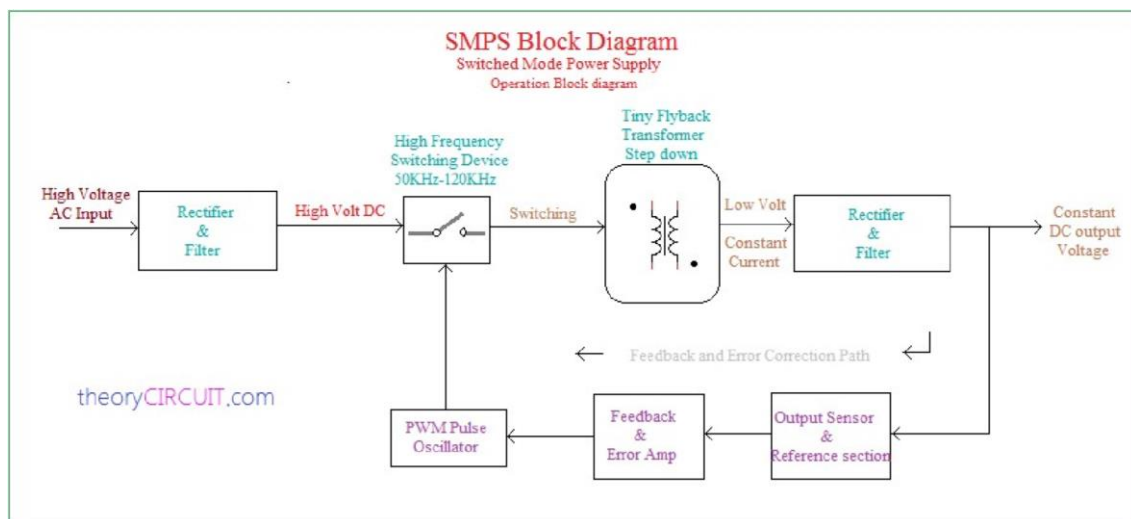

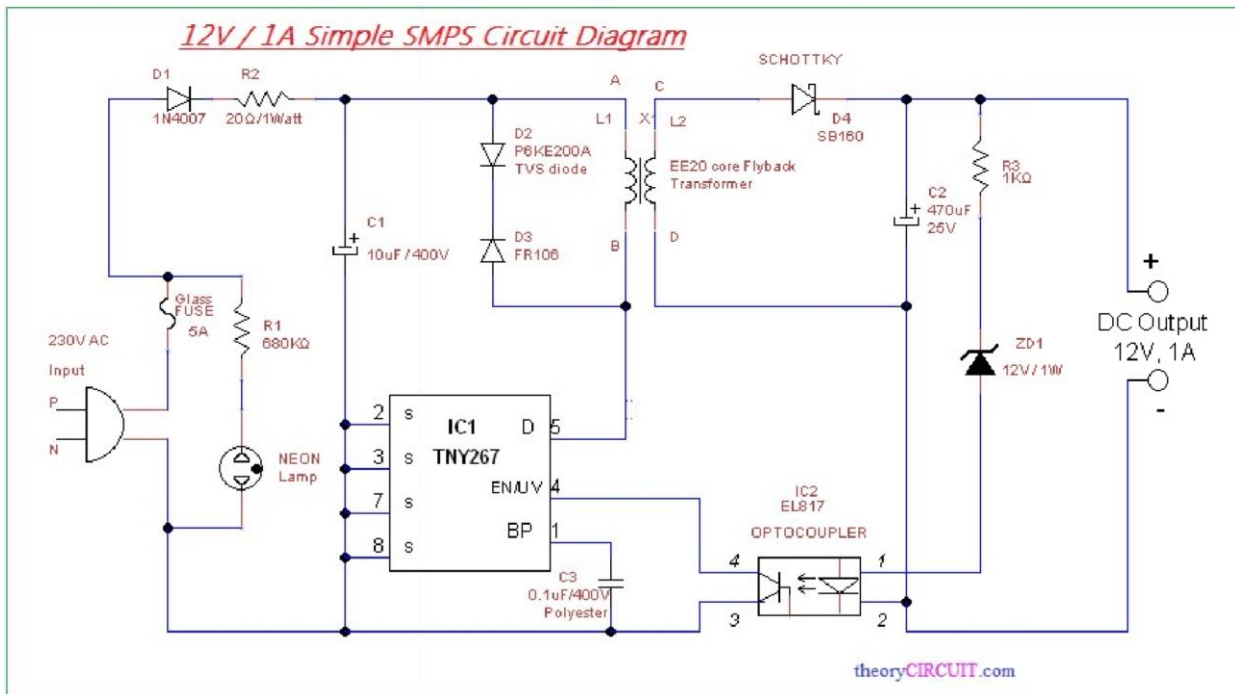

(SMPS BLOCK DIAGRAM)
(SMPS CIRCUIT DIAGRAM)

Procedure:

Setup:

- a. Connect the SMPS unit to the power supply and ensure proper grounding.
- b. Connect the DC load resistor to the output of the SMPS.
- c. Connect the multimeter across the output terminals of the SMPS to measure the output voltage.
- d. Record the rated output voltage of the SMPS. Load Regulation Testing:
 - a. Set the input voltage of the SMPS to its rated value.
 - b. Apply no load initially (open circuit).
 - c. Measure and record the output voltage with no load.
 - d. Gradually increase the load on the SMPS in predetermined steps.
 - e. At each step, measure and record the output voltage.
 - f. Calculate the percentage change in output voltage for each load step relative to the no-load voltage.

Line Regulation Testing:

- a. Maintain a constant load on the SMPS.

- b. Adjust the input voltage from the power supply in predetermined steps, simulating line voltage variations.
- c. At each step, measure and record the output voltage.
- d. Calculate the percentage change in output voltage for each input voltage step relative to the rated input voltage.

Observation Table:

1. Load Regulation:

Load (Amps)	Output Voltage (V)	Percentage Change in Voltage
0 (No Load)		
Step 1		
Step 2		
...		
Maximum Load		

2. Line Regulation:

Input Voltage (V)	Output Voltage (V)	Percentage Change in Voltage
Rated Voltage		
Step 1		
Step 2		
...		
Maximum Voltage		

Conclusion:

EXPERIMENT NO-10

AIM OF RHE EXPERIMENT:

Study the basic common faults in LED TV.

Equipment Required:

1. LED TV with various common faults (e.g., no power, no display, distorted images, etc.)
2. Screwdrivers and basic tools for disassembly
3. Multimeter
4. Oscilloscope (optional)
5. Soldering iron and soldering equipment
6. Test patterns or video source for testing

LED TVs can experience various common faults due to electronic, mechanical, or component-related issues. These faults may include power-related problems, display issues, audio problems, or issues with connectivity. The experiment aims to diagnose and understand the common faults and their underlying causes.

Procedure:

Selection of Faulty LED TV:

- a. Select an LED TV with common faults. Ensure it has various issues that can be examined.

Inspection:

- a. Examine the LED TV for external physical damage.
- b. Observe the TV's behavior when powered on. Note the symptoms of the faults, such as no power, no display, distorted images, or audio issues.

Disassembly:

- a. Disassemble the LED TV carefully using appropriate tools.
- b. Examine the internal components, including the power supply, mainboard, backlighting, and connectors.

Voltage and Component Testing:

- a. Use a multimeter to check the power supply voltages to identify any voltage-related issues.
- b. Inspect the components on the mainboard and power supply board for visible damage or defects.
- c. Use an oscilloscope, if available, to analyze waveforms and signals.

Repair and Component Replacement:

- a. Identify faulty components and replace them.

Common components that may need replacement include capacitors, resistors, and integrated circuits.

- b. Soldering may be required for component replacement. Testing:

- a. After component replacement, reassemble the TV.
- b. Power on the TV and assess whether the common faults have been resolved.
- c. Test the display quality, audio functionality, and connectivity.

Observation Table:

Fault Description	Symptoms	Component(s) Replaced	Results (Fault Resolved/Not Resolved)
No Power	TV doesn't power on		
No Display	No image on the screen		
Distorted Images	Display anomalies or artifacts		
Audio Issues	No sound or distorted audio		

Conclusion: